

GOOD PACKING GOOD SERVICES

SURFON®

上海固好包装机械有限公司

SHANGHAI KUKO PACKING MACHINERY CO., LTD.

上海地址：松江区强业路658号E幢（201602）

Add. : No. 658-E, Qiangye Road, Songjiang District, Shanghai, 201602, China

昆山分厂地址：江苏省昆山市周庄镇高勇东路1号

Kunshan Factory Add. : No.1, East Gaoyong Road, Zhouzhuang Town, Kunshan, Jiangsu Province, 215325, China

Tel: +86-(0)21-6974 6020/6974 4452/ 5226 5219

Fax: +86-(0)21-6221 9769

服务热线：400-698-6306

E-mail: info@goodpacking.com.cn

Http://www.goodpacking.com.cn



原来包装可以更轻松

The original packaging can be more easily



上海固好包装机械有限公司

SHANGHAI KUKO PACKING MACHINERY CO., LTD.



## 企业简介 Company

### Introduction

上海固好包装机械有限公司创办于2004年，位于上海市松江区，是上海市人民政府认定的高新技术企业。我司已通过ISO9001:2008质量管理体系认证及CE认证，专业致力于后段自动化包装设备的研发和制造。目的是帮助客户提高工作效率，节省人力物力，降低企业生产成本。可以根据客户各种需求研发和制造出适合于不同客户使用的自动化包装机械设备，在不断研发和制造后段自动化包装设备的同时，为了满足各类客户的需求，并致力于单机的研发和制造，主打产品有：封切收缩机、无人化自动整合系统设备、输送流水线等标准机械和非标准机械。

我司拥有国际先进的设备及技术，采用美国、英国、德国、日本、意大利、瑞士、台湾等国家和地区的先进零配件及电路电器等。已积累了丰富的机械设计、自动化控制和包装机械制造经验，多年来更是大量吸纳了高校机械、电子和自动化类高科技专业人才及企业管理类人才，长期与上海、江苏等政府部门、多所高校进行校企和产学研合作，进一步加强了我公司技术和自主研发团队能力及提升我公司管理的现代化、规范化、标准化和国际化，以求更大可能地增加我公司包装机械产品的技术含量，降低企业生产成本和产品市场销售价格，提高了包装机械产品的性价比，让用户得到更高质量的售前售后服务。我司已拥有几十项实用型专利及发明专利。

**固好企业方针：**专业制造、精益求精；规模经营，信誉保证。我司包装机械产品具有优质、高效、节能、环保、美观、结实、耐用等优点。因此，我司包装机械产品深受广大用户的欢迎和信赖，畅销于海内外。您的包装专家，我们“智”造！

**固好创业精神：**诚信。我公司提倡用户至上的原则，一切包装机械的设计均以客户的利益为出发点，不断吸收客户的反馈意见，并根据其意见改进公司产品，同时，如果贵公司有特殊的要求，我司也愿意为您定制包装机械产品。凡我公司的包装机械产品，一律提供一年的免费保修期和机器的终生维护服务。我们坚信：人要衣装，货要精装。

有何意见和建议，请与我公司客服部联系。您的意见对我们很重要，正如您对我们很重要一样！

因为专业——所以我们知道自己的不足；  
因为认真——所以我们不允许自己的失误；  
因为诚信——所以我们只做自己的强项；  
因为局限——所以我们寻找多方的合作；  
因为感谢——所以我们要求回报客户。

总经理提词

人要衣装 货要精装 中国“智”造



Shanghai Kuko Packing Machinery Co., Ltd. was established in 2004, located in SongJiang District, Shanghai, China. We are high-tech firm which has been recognized by Shanghai Government and has passed ISO9001: 2008 certificate, as well as CE certificate. We specialize in the segment of automatic packaging equipment development and manufacturing. In order to help customers to improve efficiency, save resources and reduce production costs. We can research and manufacture automatic packaging machinery according to the customer's specific requirements. Besides the automatic packaging machine, we also committed to the development and manufacture of packaging machinery. Our main products include: sealing & shrink wrapping machine, automatic integration of unmanned systems equipment, conveyors and other standard & non-standard machinery.

With the advanced equipments, technology and advanced circuit devices, spare parts from the United States, U.K., Germany, Japan, Italy, Switzerland, Taiwan and other countries & regions, our company has accumulated rich experience of mechanical design, automatic controller and the manufacturing of packaging machinery. Over the years, with absorbing a large amount of professional talent in the field of mechanical, electronics, automatic technology and management, and long-term cooperation with Shanghai, Jiangsu and other government departments, colleges and universities, which strengthened our technology and the ability of R&D team and promoted our company management modernization, standardization, and internationalization. These measures increase our packing machine's technology, reduce production costs and product's market price, improve the cost-effective of our products, and allow users to get higher quality pre-sales and after-sales service. Our company already has dozens of practical patents and invention patents.

**KUKO's Enterprise Policy:** Professional manufacture, excellence, scale operation and credibility. Our packaging machines have advantages of high quality, high efficiency, energy-saving, environmental protection, beautiful, strong, durable etc, so we are very popular among the customers in the domestic and the overseas markets. Your packaging experts, we "wisdom" made!

**KUKO's Entrepreneurial Spirit:** integrity. Our company advocates the principle--users-supremacy. All the designs of the packing machine are based on the customers' interests. And then improve our products according to their views by absorbing customers' feedback. Also, if your esteemed company has special requirements, we are willing to customize for you. Our company will provide one year's warranty and lifetime maintenance services. We are convinced that: The tailor makes the man while the packer beautifules the goods!

Any comments and suggestions, please contact our customer-service department. Your opinion is important to us, just like you are very important to us!

Because professional - So we know our deficiencies;  
Because serious - So we do not allow our own mistakes;  
Because integrity - So we focus on own strengths;  
Because the limitations - So we are looking for multi-party cooperation;  
Because thanks - So we have to return customers.





## 企业荣誉

### Company Honor

固好的自信与骄傲来自客户的好评，来自政府和社会的支持，来自业界同仁的信任。翻出平日里的荣誉证书，固好人坚信：已有的荣誉与骄傲，应让其在我们手中延续；将有的荣誉与骄傲，还会从我们手中创造……

Self-confidence and prides of KUKO staffs come from good customer evaluations, supports from the government and society and trusts from industry colleagues. Opening our certificates of honor, KUKO staffs believe: Existing honor and prides should be allowed to continue in our hands; the prospective honor and prides will be created from our hands...



Shanghai Kuko Packing Machinery Co., Ltd.

GOOD PACKING GOOD SERVICES

SURFON®

## 合作伙伴 Cooperative Partners

我们的战略伙伴遍及各个领域；我们强强联合，所向披靡。

Our strategic partners are throughout all areas; we join together, carrying the world before it.



## 供应商 Main Suppliers



## 主要客户 Main Customers







- GH-6030AF Fully-auto Horizontal Double Side Sealer which is developed for special big items adopts advanced high speed double-side sealing technology. It has up & down single film rollers. The film is in sync with the items. While the items are going forward, the side sealing system starts to seal and cut the up & down film that keeps good sealing;
- Continuous sealing & cutting and no limits of the item length make it particularly suitable for longer, wider and heavy products' fully-closed packaging with PE film, such as doors, furniture, ladders, mattresses and other heavy and oversized objects;
- The waste film can be winded automatically for easily clean-up;
- Side sealing lines can be adjusted to the desired position which based on the product's height in order to achieve excellent sealing strength results;
- For 0.04 ~ 0.18mm thickness PE shrink film;
- Input & output conveyors and colored film positioning function can be added as per customer demand;
- Humanized touch smart operation interface is convenient for the operator to use;
- Fatek PLC program controller achieves the integrations of mechanism, electricity and pneumatic;
- Imported photo sensors to detect the horizontal and vertical section to satisfy different products' packaging;
- Assorted shrink tunnel SF-15040E uses imported double air circulation motors, so that the hot air in the oven can spread more evenly to get a good shrink effect;
- PE high strength film is suitable for long distance transportation and frequent handling that can avoid damage and keep away from moisture.

产品特点 Product Features

- GH-6030AF全自动水平式双边封切机是采用国际先进的高速边封技术，根据大型包装物特殊开发的一款新型的全自动封切机，采用上下各两卷单片筒膜，膜与产品同步，在产品前进时，边封装置开始对上下两片膜进行热封切断，封口效果好；
- 连续封口切断，对产品的长度没有限制，特别适合较长、宽以及重型产品的全封闭包装，如门板、家具、梯子、床垫等；
- 本机将对包装时产生的废料自动进行收卷，方便清理；
- 边封口线可以根据产品包装的高度调节到需要的位置从而达到最佳的封口强度效果；
- 适用于0.04~0.18mm厚度的PE热收缩膜；
- 可根据客户的需要增加前后输送机构及彩膜定位功能；
- 人性化的触摸智能操作界面，方便操作者使用；
- 永宏PLC程序控制器，实现机、电、气一体化；
- 进口水平及垂直产品检测光电各一组，可根据不同包装物需要切换；
- 配套收缩包装机SF-15040E采用进口双运风循环电机，使炉腔内热风散布更均匀达到良好的收缩效果；
- 采用PE高强度膜，适合长途运输和频繁搬运以达到保护产品防损伤、防潮等效果。

技术参数 Technical Parameter

型号 Model	GH-6030AF	SF-15040E
功率 Power	8kw	30kw
电源 Power Supply	AC 380/220V 3PH 50/60Hz	AC 380/220V 3PH 50/60Hz
最大包装尺寸 Max. Packing Size LxWxH	L(unlimited) W≥300mm W+H≤1250mm, H≤250mm	2500 × 1000 × 250mm
炉腔尺寸 Tunnel Size LxWxH	/	3000 × 1500 × 400mm
横封刀长度 Horizontal Blade Length	1300mm	/
空气温度 Air Temperature	300°C	300°C
工作台高度 Table Height	825 ± 25mm	825 ± 25mm
包装速度 Packing Speed	15m/min.	0~18m/min.
外接气源 External Air Source	6~8kg/cm <sup>2</sup>	/
适用收缩膜 Shrink Film	PE	PE
机械尺寸 Machine Size LxWxH	2455 × 1950 × 1960mm	5000 × 1850 × 1850mm
包装尺寸 Package Size LxWxH	2505 × 2000 × 2110mm	5050 × 1900 × 2000mm
毛净重 G./N. Weight	1600/1500kgs	2500/2400kgs







技术参数 Technical Parameter

型号 Model	功率 Power	电源 Power Supply	炉腔尺寸 Tunnel Size L x W x H	最大包装尺寸 Max. Packing Sizes	横封刀尺寸 Horizontal Blade Size	外接气源 Air supply	包装速度 Packing Speed	适用收缩膜 Shrink Film	机械尺寸 Machine Size L x W x H	包装尺寸 Package Size L x W x H	毛净重 G./N. Weight
GH-3015CM	4kw	AC 220V 1/3PH 50/60Hz	/	W+H≤450mm W≤300mm H≤150mm	450mm	6~8 kg/cm <sup>2</sup>	80~100pcs/min.	POF	2735×1480×1300mm	2785×1530×1450mm	1200/1100kgs
SF-5030LG	21kw	AC 380/220V 3PH 50/60Hz	1500×500×300mm	W400×H200mm	/	/	0~40m/min.	POF	2400×985×1315mm	2360×1010×1490mm	580/560kgs

产品特点 Product Features

- 本机采用先进的边封及往复式横封技术，具有持续封口动作。伺服控制系列，能在高效的前提下实现完美的热缩包装；
- 伺服马达控制动作，机器在高速运行过程中，表现稳定、可靠、连续包装过程中产品能顺畅的传送，不会出现滑动及移位现象；
- 整机配备自适应给料系统，可根据主机包装的速度自动调整给料系统的速度与之匹配；
- 当人工放料或漏放产品时整机会处于待机状态，直到有连续的产品通过时，自动重启；
- 操作界面采用轻触式显示屏，各种设置操作均可轻松完成，同时可提前贮存多种产品数据，包装不同产品及要求时只需调整贮存数据，简单、便捷。具备自动监测功能，错误信息将在显示屏上出现，方便操作人员及时矫正；
- 包装过程中，连续横封切，不会出现裂口，废膜较传统设备将节省10%~20%，为客户节省包装成本；
- 整机的进料、送膜、封切、收缩、出料均采用伺服马达控制，保证高速运行平稳；可增加彩膜定位功能；
- 可根据不同产品，配置相应的进料输送系统，与生产线连接，实现自动化包装，节省人工成本；
- SF-5030LG采用先进的下部吹风技术，充分利用热能，提高能效，节省用电量。风量由变频器控制；同时炉内的风向及底部风量大小可根据需要调节；
- 炉腔有可视窗口，可以观察到产品在炉腔内的热收缩过程，同时炉腔上部分可以打开，便于清洁及维护；
- 根据客户的产品及要求可选择皮带式进料或指推式进料输送线；
- 可任意调整输送线的速度，控制产品与产品之间的间隙，保证封切时产品的距离整齐一致；
- 适用于CD、相框、书刊、杂志、电子产品等批量化生产。

- This machine uses advanced side sealing and continuous motion horizontal sealing which have continuous sealing function. Servo control series realize perfect shrink wrap with high efficiency;
- Servo motor action performs stable, reliable, continuous packaging process in high speed running, smooth transport without product move and stop;
- Equipped with self-adapt feeding system adjust feed speed automatically according to speed of host machine;
- Whole system be standby status when feed by manual or miss feeding, switch-on automatically till to continued product feeds;
- Color touch operator interface accomplish all working date easily, the panel with date memory for various products allows quick changeovers by simply calling up the needed date from the database. Error of shows on screen with automatic inspect function make easier for operator to do emendation;
- Continuous cross seal without gap at sealing line, waste film can be saved 10%~20% compared with other traditional equipments which save customer cost a lot;
- Whole performance controlled by servo motors includes feeding, film releasing, sealing, shrinking and out feeding, make it smooth running in high speed;
- Able to increase logo locate function for printed film;
- Equipped with suitable feeding system to connect customer production line for different products, realize fully automatic packaging to save labor cost;
- SF-5030LG adopts advance blowing from the bottom of the tunnel, full use of heat to arise energy efficiency. Frequency inverter controls blowing, adjustable blowing direction and volume form bottom;
- Visible window shows shrink process in tunnel, the top of tunnel can be opened for easy clear and maintenance;
- Optional belts feeding or fingers pushing conveyor for meefing products or customer's requests;
- Adjustable conveyor speed which controls equal distance among products make sure seal consistent sealing;
- Applicable for mass packaging like CD, photo frame, books, magazine, electronic products etc.

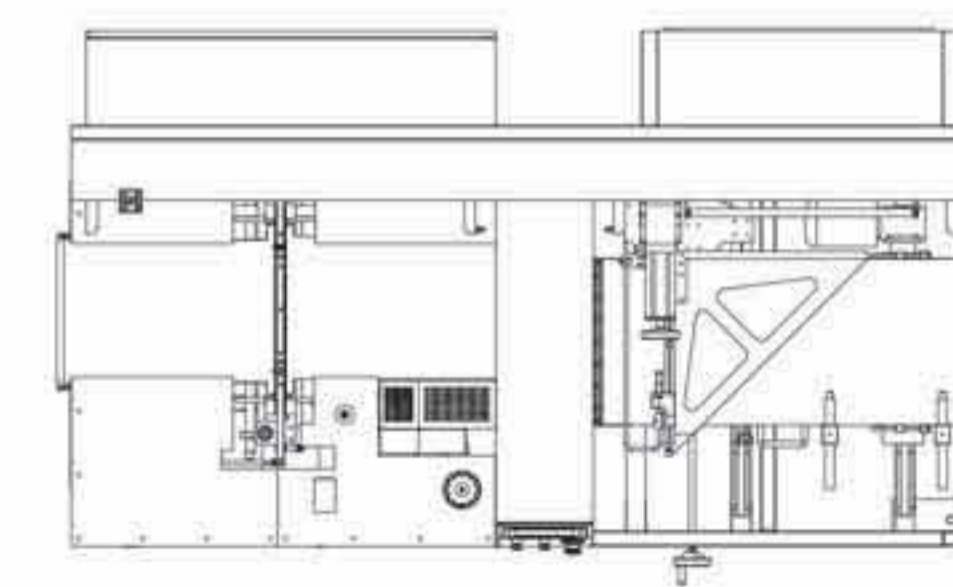
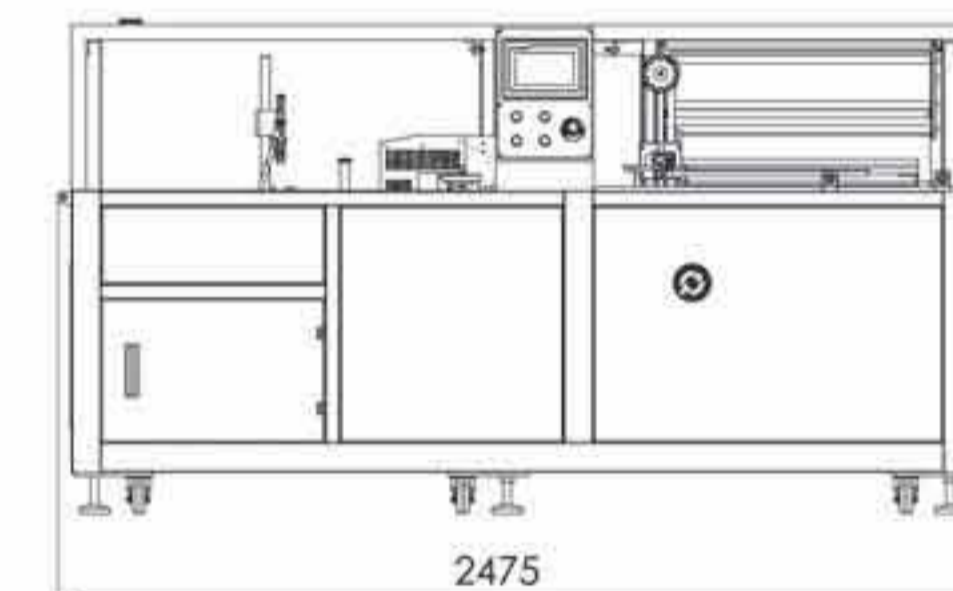



## 全自动（中速型）边封封切收缩包装机

GH-3015ML+SF-5030LG (Fully-auto Side Sealer & Shrink Tunnel(Medium Speed))



### 产品特点 Product Features

- GH-3015ML是我公司自主研发的一款全自动无人化操作的边封包装机。自动进料、输送、入袋、封口、收缩一次性完成，因此被广泛用于大批量生产包装的流水作业，工作效率高，且适用不同高度和宽度的产品；
- 封口部分横刀采用垂直式驱动，纵刀采用国际先进的恒温侧封刀，封口线直而牢固。可保证封切线在产品的中间位置，可以连续封口切断，达到完美的封口效果；
- 恒温加热封切系统可用于封切POF等各种工业标准的收缩膜。包装规格大小不同的产品，只需用手轮调整即可完成，增加可靠性，更加容易操作；
- 纵封刀可持续性的做封切动作，产品长度不受限制；
- 本机采用最先进PLC可编程控制器，具有安全保护及警报装置，且封切系统能持续流畅做出封口动作，不用更替，检修操作非常简易；
- 送料长度控制经电眼侦测和定时器组合，精准地控制胶膜长度，使收缩效果更易控制；
- 加装水平及垂直电眼共两组电眼，便于切换选择，对于薄或小的包装物，也可轻易完成封口包装作业；
- 自动卷取废料，采用单独马达控制，不会过于松弛或过紧而拉裂，废料容易拆卸；
- 可根据客户要求，添加真空送料和充气功能使收缩产品更美观；
- 可根据需要选配前端动力进料线及后端无动力贮物台；
- 相框、画框、铝型材、木质品等产品单个包装或组合包装，适用于批量化的生产长型的物料。

Shanghai Kuko Packing Machinery Co., Ltd.

GOOD PACKING GOOD SERVICES

SURFON®

- GH-3015ML is our company independently developed unmanned fully-auto side sealer which is widely used in mass packing production. Automatic feeding, conveying, putting into the bag, sealing and shrinking can complete in one time. It can be used for different height and width products with high working efficiency;
- Horizontal Blade of sealing part uses vertical drive; side blade adopts the international advanced thermostatic side sealing knife. Sealing line is straight and strong which can guarantee the sealing in the middle of the product. It can keep continuously sealing and cutting to achieve perfect sealing effect;
- Temperature heating systems can be used for sealing various standard industrial films, such as POF shrink film. Only adjust the hand wheel to pack different sizes of the products that increase reliability and operate easier;
- Side blade sealing continuously makes the unlimited length of the product;
- The machine adopts the most advanced PLC programmable controller, meanwhile it also has safety protection and alarm device. The sealing system can continue to make a smooth sealing action without replacement. The maintenance is very simple;
- The feeding length controlled by photo sensor and time relay which regulates film length precisely and makes the shrinking under control;
- In addition the installation of two groups of horizontal and vertical electric eyes are easy to switch choice for thin or small package that can easily complete sealing packaging operations;
- Auto waste film collection which is controlled by single motor will not make the film too loose or too tight. It is easy to remove the waste film;
- According to customers' needs, vacuum feeding and gas charging can be added to make more beautiful shrinking;
- We also can equip the machine with in feed power line and outlet non-power storage table;
- It can be used for frame, aluminum, wooden products with single package or a combination of packaging. The machine is suitable for mass production of long materials.

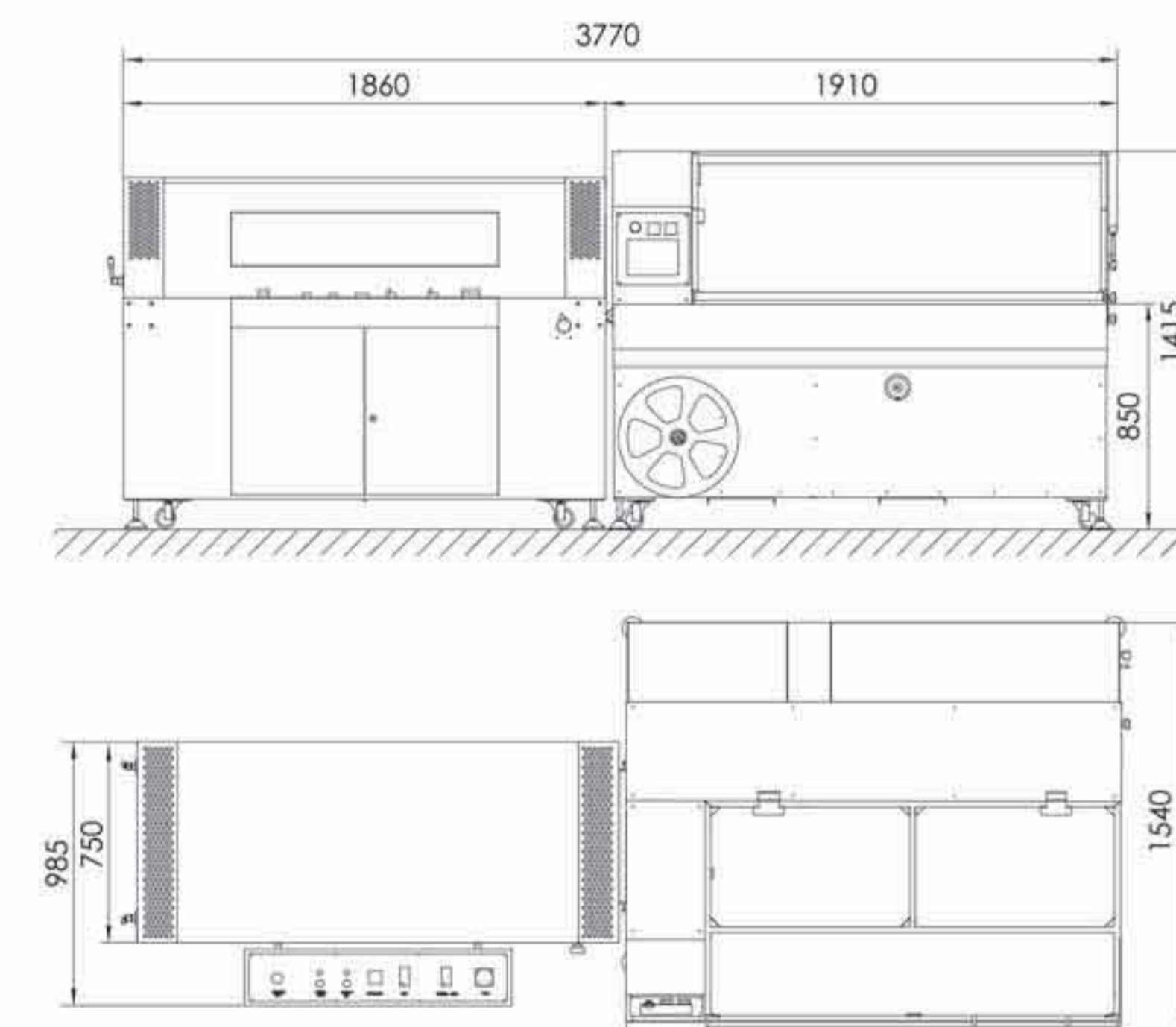

### 技术参数 Technical Parameter

型号 Model	功率 Power	电源 Power Supply	最大包装尺寸 Max. Packing Size	炉腔尺寸 Tunnel Size L x W x H	包装速度 Packing Speed	横封刀长度 Horizontal Blade Length	外接气源 External Air Source	适用收缩膜 Shrink Film	机械尺寸 Machine Size L x W x H	包装尺寸 Packaging Size L x W x H	毛净重 G./N. Weight
GH-3015ML	1.8kw	AC 380/220V 3PH 50/60Hz	L(unlimited) W+H430mm; Hs150mm	/	20~40m/min.	490mm	6~8kg/cm <sup>2</sup>	POF	2115 x 1547 x 1275mm	2060 x 1600 x 1420mm	670/640kgs
GH-5515ML	2kw	AC 380/220V 3PH 50/60Hz	L(unlimited) W+H550mm; Hs150mm	/	20~40m/min.	700mm	6~8kg/cm <sup>2</sup>	POF	2315 x 1747 x 1275mm	2370 x 1800 x 1420mm	930/880kgs
GH-7015ML	2.2kw	AC 380/220V 3PH 50/60Hz	L(unlimited) W+H750mm; Hs150mm	/	20~40m/min.	900mm	6~8kg/cm <sup>2</sup>	POF	2515 x 1947 x 1275mm	2570 x 2000 x 1420mm	1200/1150kgs
SF-5030LG	21kw	AC 380/220V 3PH 50/60Hz	W400 x H200mm	2000 x 500 x 300mm	0~30m/min.	/	/	POF	2400 x 985 x 1265mm	2360 x 1010 x 1440mm	560/540kgs





产品特点 Product Features

- GH-5030LH 是我公司特别研发的一款全自动无人化操作的边封包装机，广泛应用于大批量生产包装的流水作业，自动进料、输送、封口、收缩一次性完成，工作效率高，适用不同高度和宽度的产品；
- 封口部分横刀采用垂直式驱动，纵刀采用国际先进的恒温侧封刀，封口线直而牢固，可保证封切线在产品的中间位置，达到完美的封口效果；
- 包装规格大小不同的产品，只需要用手轮调整即可完成，增加可靠性，更加容易操作；
- 适用于比较高的产品；
- 本机采用先进的西门子PLC可编程控制器，具有安全保护及警报装置，且封切系统能持续流畅做出封口动作，无须更替，检修操作非常简；
- 送料长度控制经电眼侦测和定时器组合，精准地控制胶膜长度，使收缩效果更易控制；
- 加装水平及垂直工两组电眼，便于切换选择，对于薄或小的包装物可轻易完成封口包装作业；
- 自动卷取废料，采用单独马达控制，不会过于松弛或者过紧而拉裂，废料容易拆卸；
- 自动吹气功能；
- 可根据需要选配前段动力进料及后端无动力贮存台。

- GH-5030LH is an especial fully-auto unmanned operation side sealer by our company's independent research and development, which is widely used in mass production assembly line with auto-feeding, conveying, sealing, shrinking in one time. It is high working efficiency and suits for the products of different height and width;
- The horizontal blade of sealing part adopts vertical driving, while the side blade uses international advanced thermostatic cutter; The sealing line is straight and strong and we can guarantee seal line in the middle of the product to achieve perfect sealing effect; This side sealing machine is different from common side sealing machine that the horizontal blade is behind of side sealing part;
- When it packs different sizes, the adjustment is very simple by rotating the hand wheel to increase the reliability;
- Suitable for big height products;
- The machine adopts the most advanced Siemens PLC programmable controller, with safety protection and alarm devices, while the sealing system can have a continuous sealing order without replacement; Maintenance is very simple;
- Feeding length controls through a combination of electric eye detection and time relay to control precise film length that makes it easier to control the contraction effect;
- Two groups of horizontal and vertical electric eyes are easy to switch for thin or small packages which can easily complete sealing packaging operations;
- Automatic rolling waste material : Using a separate motor to control which is not too loose or too tight to crack and is easy to remove the waste;
- It has automatic blowing function;
- Front in feeding power conveyor and back non-power storage table can be selected as your demands.

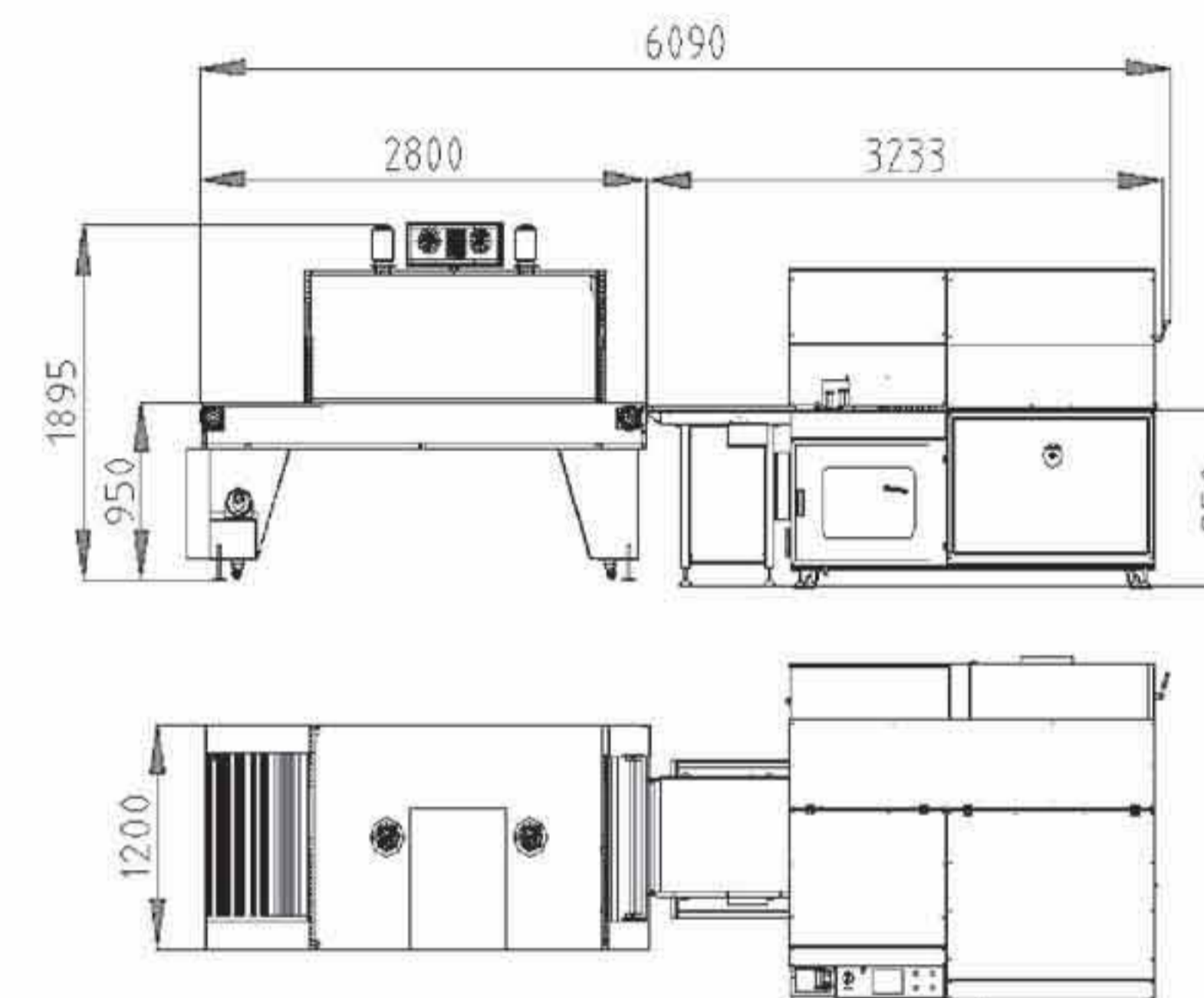

技术参数 Technical Parameter

型号 Model	功率 Power	电源 Power Supply	最大包装尺寸 Max Packing Sizes L x W x H	炉腔尺寸 Tunnel Size L x W x H	横封刀长度 Sealing Blade Length	外接气源 External Air Source	适用收缩膜 Shrink Film	机械尺寸 Machine Size L x W x H	包装尺寸 Packaging Size L x W x H	毛净重 G./N. Weight
GH-5030LH	2.9kw	AC380/220V 3PH 50/60HZ	L(unlimited), W+H<=800mm, H<=300MM	900mm	/	6~8 kg/cm <sup>2</sup>	POF	3233 x 1800 x 1700mm	2700 x 1850 x 1850mm	1350/1300kgs
GH-8030LH	3.1kw	AC380/220V 3PH 50/60HZ	L(unlimited), W+H<=1100mm, H<=300MM	1200mm	/	6~8 kg/cm <sup>2</sup>	POF	3300 x 2120 x 1750mm	2750 x 2220 x 1850mm	1500/1450kgs
SF-8050	27kw	AC380/220V 3PH 50/60HZ	W700x H400mm	1800 x 800 x 500mm	/	6~8 kg/cm <sup>2</sup>	POF	2800 x 1240 x 1800mm	2900 x 1290 x 1850mm	850/800kgs





产品特点 Product Features

- GH-3015L是我公司自主研发的一款全自动无人化操作的经济型边封包装机，广泛用于大批量生产包装的流水作业，自动进料、输送、封口、收缩一次性完成，工作效率高，适用不同高度和宽度的产品；
- 封口部分横刀采用垂直式驱动，纵刀采用国际先进的恒温侧封刀，封口线直而牢固，可保证封切线在产品的中间位置，达到完美的封口效果；
- 包装规格大小不同的产品，只需用手轮调整即可完成，增加可靠性，更加容易操作；
- 本机采用先进的永宏PLC可编程控制器，具有安全保护及报警装置，且封切系统能持续流畅做出封口动作，无须更替，检修操作非常简易；
- 送料长度控制经电眼侦测和定时器组合，精准地控制胶膜长度，使收缩效果更易控制；
- 加装水平及垂直电眼共两组电眼，便于切换选择，对于薄或小的包装物可轻易完成封口包装作业；
- 自动卷取废料，采用单独马达控制，不会过于松弛或过紧而拉裂，废料容易拆卸；
- 可根据客户需要，添加自动吹气功能；
- 可根据需要选配前端动力进料线及后端无动力置物台。

- GH-3015L is an economical fully-auto unmanned operation side sealer by our company's independent research and development, which is widely used in mass production assembly line with auto-feeding, conveying, sealing, shrinking in one time. It is high working efficiency and suits for the products of different height and width;
- The horizontal blade of sealing part adopts vertical driving, while the vertical cutter uses international advanced thermostatic side cutter; The sealing line is straight and strong and we can guarantee sealing line in the middle of the product to achieve perfect sealing effect;
- When it packs different sizes, the adjustment is very simple by rotating the hand wheel to increase the reliability;
- The machine adopts the most advanced Fatek PLC programmable controller with safety protection and alarm devices, while the sealing system can have a continuous sealing order without replacement; Maintenance is very simple;
- Feeding length controls through a combination of electric eye detection and time relay to control precise film length that makes it easier to control the contraction effect;
- Two groups of horizontal and vertical electric eyes are easy to switch for thin or small packages which can easily complete sealing packaging operations;
- Automatic rolling waste material: Using a separate motor to control which is not too loose or too tight to crack and is easy to remove the waste;
- It has automatic blowing function;
- Front in feeding power conveyor and back non-power storage table can be selected as your demands.

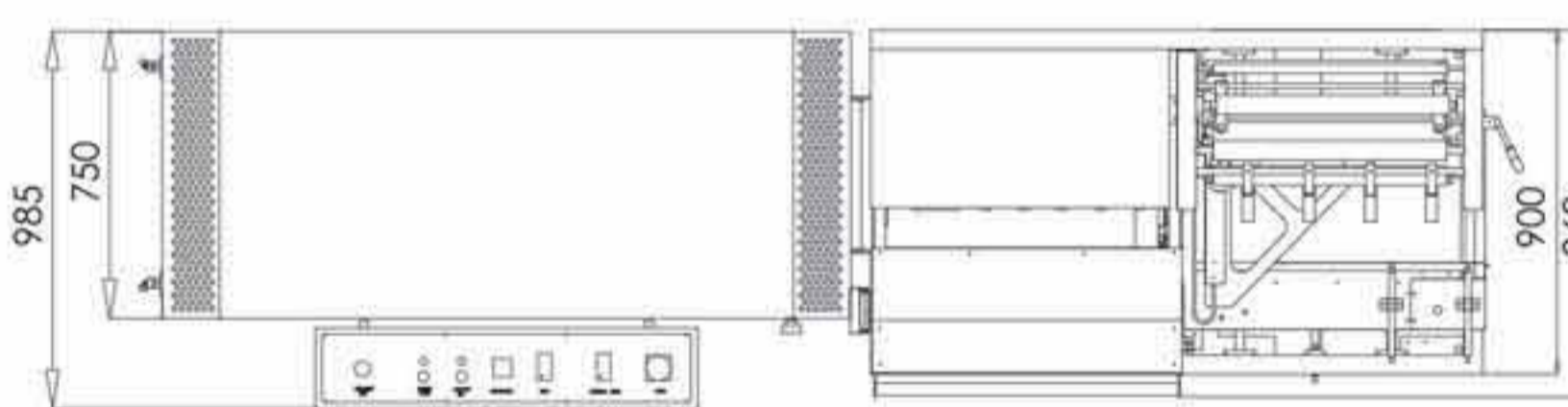
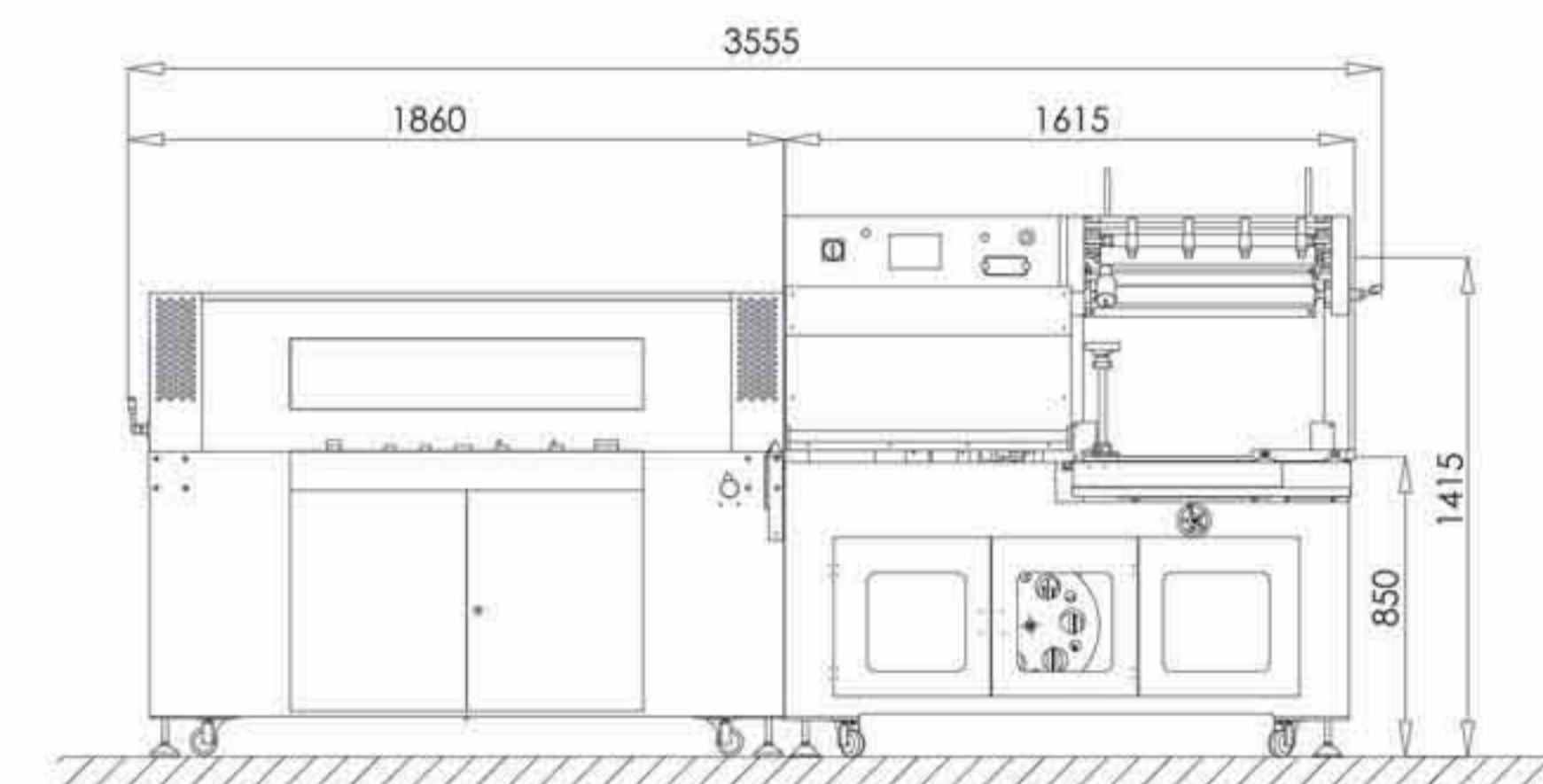

技术参数 Technical Parameter

型号 Model	功率 Power	电源 Power Supply	最大包装尺寸 Max Packing Sizes L x W x H	炉腔尺寸 Tunnel Size L x W x H	横封刀长度 Sealing Blade Length	包装速度 Packing Speed	外接气源 External Air Source	适用收缩膜 Shrink Film	机械尺寸 Machine Size L x W x H	包装尺寸 Packaging Size L x W x H	毛净重 G./N. Weight
GH-3015L	1.8kw	AC 380/220V 3PH 50/60Hz	L(unlimited)xW300xH150mm	/	490mm	15m/min.	6~8kg/cm <sup>2</sup>	POF/PE	1748 x 975 x 1650mm	1710 x 1005 x 1680mm	550/525kgs
GH-5515L	2kw	AC 380/220V 3PH 50/60Hz	L(unlimited) x W500 x H150mm	/	700mm	15m/min.	6~8kg/cm <sup>2</sup>	POF/PE	2235 x 1690 x 1425mm	2285 x 1740 x 1475mm	955/920kgs
GH-7015L	3kw	AC 380/220V 3PH 50/60Hz	L(unlimited) x W650 x H150mm	/	900mm	15m/min.	6~8kg/cm <sup>2</sup>	POF/PE	2210 x 1900 x 1330mm	2260 x 1950 x 1380mm	1220/1180kgs
SF-5030LG	16kw	AC 380/220V 3PH 50/60Hz	W400 x H200mm	1500 x 500 x 300mm	/	0-20m/min.	/	POF	1865 x 985 x 1260mm	1870 x 1010 x 1440mm	482/453kgs





产品特点 Product Features

- GH-450LV是我公司自行研发的一款全自动无人化操作的L型封切机，广泛用于大批量生产包装的流水作业，自动进料、输送、封口、收缩一次性完成，工作效率高，特别适用于较高较大尺寸的产品；
- 封口部分为上下垂直式驱动，封口接触面均匀。垂直式驱动可克服传统“L”型自动封切包装机出现的折皱和封口线不在产品中间的问题，达到极佳的封口效果；
- 本机采用最先进PLC可编程控制器，具有安全保护及报警装置，且封切系统能持续流畅做出封口动作，不用更替，检修及操作非常简易；
- 送料长度控制经电眼与定时器组合同时控制，精准地控制胶膜长度；
- 加装水平及垂直两组电眼，便于切换选择，对于薄或小的包装物，可轻易完成封口包装作业；
- 自动卷取废料，采用单独马达控制，不会过于松弛或过紧而撕裂，废料容易拆卸；
- 包装不同高度的产品，封刀升降由电机传动，只需轻触按钮即可完成；
- SF-6040采用进口双运风电机，使炉腔内热风散布均匀，收缩后效果更加美观；
- 链杆输送采用实心钢杆外包进口硅胶管，经久耐用。亦可根据不同产品的采用不同材质的输送链；
- 变频器控制传送速度，无级调速；
- 超大风量冷却系统，产品热缩后迅速冷却定型后端可选配铝制工作台，产品包装后不会跌落地面；
- 适用于茶叶大礼包、变频器、路由器、电脑等中型物体的封切收缩包装。

- GH-450LV is one auto unmanned L Bar Sealer developed by our own company, which is widely used in the packaging assembly line of mass production. It also can automatically feed, transport, sealing, shrink once completed with high efficiency, especially for large products;
- The sealing part is made by up and down vertical driving. The surface of the sealing is even. What's more, the vertical sealing can avoid the crease and messy sealing line to achieve the perfect sealing effect;
- It adopts the most advanced PLC controller, which equipped with safety protection and alarm function. The sealing system can give the continuous and smooth sealing order without replacement. The maintenance and the operation are very simple;
- The electric eye and time relay can make a precise measurement of the film length;
- The two groups of electric eyes on the horizontal and vertical directions make sure the thin or small goods can be sealed easily;
- Separate motor is used to control the auto winding device, which make the waste film is not too loose or too tight to crack. The waste film can be easily removed;
- The sealing blade is lifted according with the height of the packaging products by the motor driving; all you have to do is just touch the button;
- SF-6040 shrink tunnel adopts the imported double recycling motor, so that the hot air in the tunnel is even to make the shrink effect more beautiful;
- The chain conveyor made of solid steel covered with imported silicone tube is very durable. Besides the chain conveyor, we also have different conveyors according the products shape and material;
- The frequency inventor controls the speed of the conveyor;
- The large wind cooling system can make the packing of the product fixed and unchangeable after shrinking. The aluminum table can be used in the back of the wind cooling system which makes sure the product will not drop;
- The machine is suitable shrink packing for tea gift bag, inverter, router, computer and other medium sizes products.

技术参数 Technical Parameter

型号 Model	GH-450LV	GH-600LV	GH-700LV	SF-6040LG
功率 Power	2.6kw	2.8kw	3kw	21kw
电源 Power Supply	AC 380/220V 3PH 50/60Hz	AC 380/220V 3PH 50/60Hz	AC 380/220V 3PH 50/60Hz	AC 380/220V 3PH 50/60Hz
炉腔尺寸 Tunnel Size L×W×H	/	/	/	2000×600×400mm
最大包装尺寸 Max. Packing Size	L+H≤400mm W+H≤300mm H≤100mm	L+H≤600mm W+H≤500mm H≤180mm	L+H≤800mm W+H≤700mm H≤180mm	W500×H300mm
封刀尺寸 Blade Length	450 x 350mm	650 x 550mm	900 x 600mm	/
包装速度 Packing Speed	20~30m/min.	20~30m/min.	20~30m/min.	0~25m/min.
外接气源 External Air Source	6~8kg/cm <sup>2</sup>	6~8kg/cm <sup>2</sup>	6~8kg/cm <sup>2</sup>	/
适用收缩膜 Shrink Film	POF	POF	POF	POF
机械尺寸 Machine Size L×W×H	1460 x 1227 x 1280mm	1760 x 1427 x 1280mm	2410 x 1644 x 1380mm	2400 x 1085 x 1365mm
包装尺寸 Package Size L×W×H	1510 x 1227 x 1430mm	1810 x 1427 x 1430mm	2460 x 1694 x 1530mm	2450 x 1135 x 1515mm
毛净重 G./N. Weight	870/820kgs	900/850kgs	1000/950kgs	500/450kgs



## 全自动L型封切收缩包装机

SF-400LA+SF-4525 Fully-auto L Bar Sealer & Shrink Tunnel



### 产品特点 Product Features

- SF-400LA是一款全自动无人化操作的“L”型封切机，广泛用于批量生产包装的流水作业，工作效率高。自动送膜打孔装置和手动调节的导膜系统以及进料输送平台，适用不同宽度及高度的产。
- SF-400LAC机型还具有密接功能，专为包装小产品设计；
- 封刀采用杜邦特弗龙涂层抗粘耐高温铝合金刀，封口不会开裂、不会焦化、不冒烟零污染；
- 配有进口检测光电，水平、垂直检测各一组，便于切换选择；对于薄与小包装物，也可轻易完成封口包装作业；
- 自动送料，长度亦能经由电眼和计时器的组合自动调节。配有感应马达，自动卷取废料；
- 当包装物尺寸变更时，通过手轮转动调节包装的尺寸，调整非常简单，不用换模具与制袋器；
- 不同大小的产品还可以搭配组合包装，以达到促销效果；
- 采用原装“奥托尼克斯”内置PID功能数显温控器。封刀温度极为灵敏与精确，同时也可随意设定；不必担心温度不精确伤及产品，封刀自身还带有自动保护功能，能有效防止误切包装物；
- 整套机器真正实现与生产线的无人化操作连接；
- 适用于软件、食品、化妆品、印刷、制药、地板、陶瓷、饮料及五金等行业的特大批量收缩包装。

Shanghai Kuko Packing Machinery Co., Ltd.

GOOD PACKING GOOD SERVICES

SURFON®

- SF-400LA is a fully automatic unmanned operation "L" type sealing machine which is widely used in mass production packaging line with high efficiency. Automatic film feeding punching device, manually adjustable film-guide system and feeding conveyor platform make the machine suitable for different width and height items. SF-400LAC has closely connecting function which specially designed for small items;
- Sealing knife uses the aluminum knife with DuPont Teflon which is anti-stick coating & anti-high temperature. So the sealing will not have cracking, coking and smoking with zero pollution;
- Equipped with imported photoelectric of horizontal and vertical detection for choice to easily finish the sealing of thin and small items;
- Automatically-feeding: the length can be auto adjusted by the sensor and time relay. Matched the reduction motor makes the waste film automatically rolling;
- When the packaging size changes, the adjustment is very simple by rotating the hand wheel without changing molds and bag makers;
- Different size products can also be packaged combinations to achieve the promotional effect;
- Using original Autonics digital temperature controller which built-in PID function. Sealing blade temperature is extremely sensitive and accurate and we can be arbitrarily set. Do not worry about hurting the product for imprecise temperature. The sealing blade itself is also equipped with automatic protection function which effectively prevent from accidental cutting;
- The entire machine realizes unmanned operation with the production line connecting;
- Applies to software, food, cosmetics, printing, pharmaceutical, floorings, ceramic, beverages, hardware and other industries' large quantities of shrink wrap.

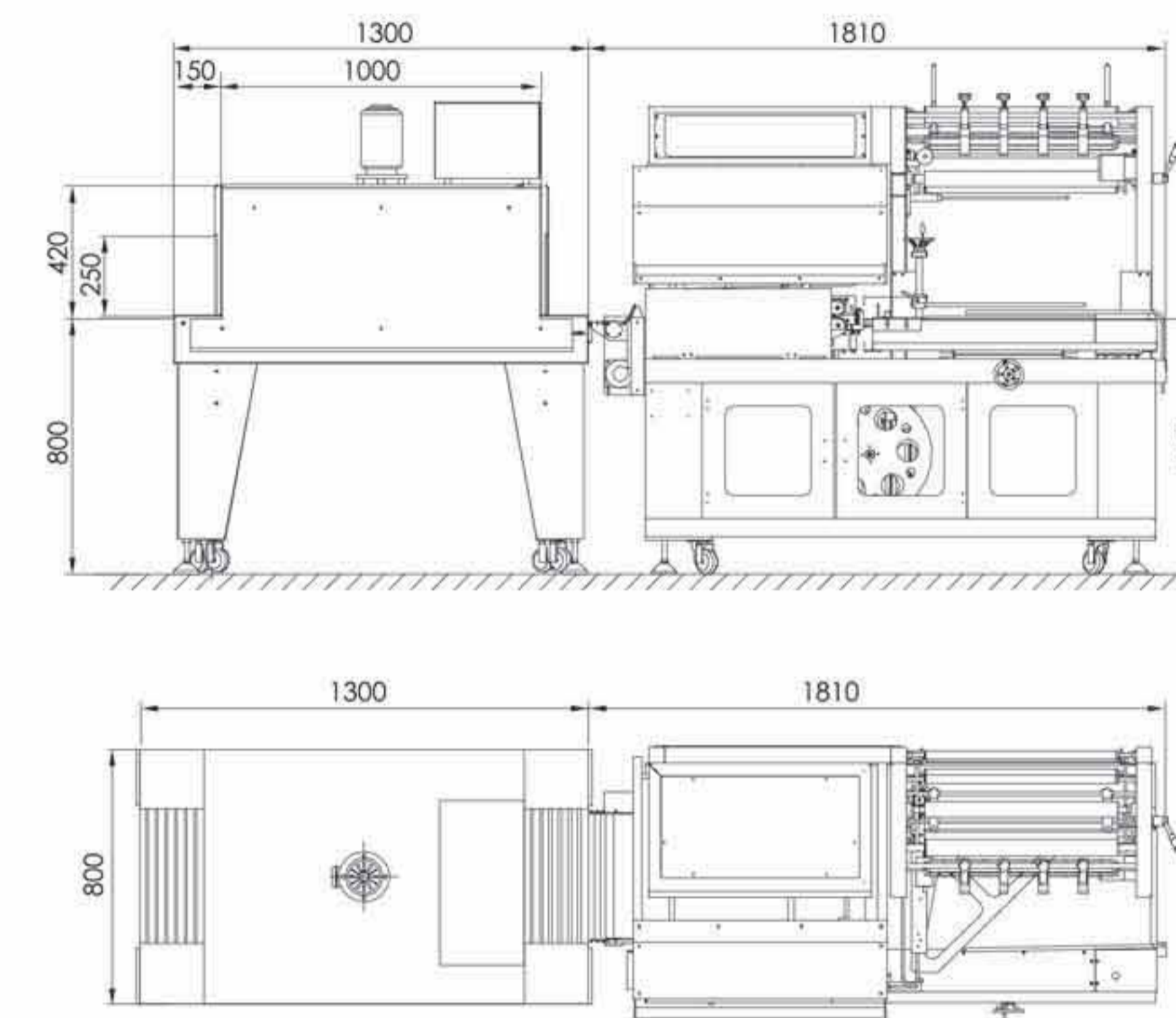

### 技术参数 Technical Parameter

型号 Model	功率 Power	电源 Power Supply	最大包装尺寸 Max. Packing Size L x W x H	最大封口尺寸 Max. Sealing size	包装速度 Packing Speed	外接气源 External Air Source	适用收缩膜 Shrink Film	机械尺寸 Machine Size L x W x H	包装尺寸 Package Size L x W x H	毛净重 G./N Weight
SF-300LAC	2.2kw	AC 220V 1/3PH 50/60Hz	L+H≤330mm W+H≤240mm H≤135mm	350 X 260mm	15m/min.	6-8kg/cm2	POF	1442 X 685 X 1538mm	1492 x 735 x 1688mm	423/393kgs
SF-400LA	2.0kw	AC 220V 1/3PH 50/60Hz	L+H≤530mm W+H≤430mm H≤135mm	550 X 450mm	15m/min.	6-8kg/cm2	POF	1860 X 880 X 1660mm	1830 x 860 x 1560mm	475/453kgs
SF-400LAC	2.3kw	AC 220V 1/3PH 50/60Hz	L+H≤530mm W+H≤430mm H≤135mm	550 X 450mm	15m/min.	6-8kg/cm2	POF	1860 X 880 X 1660mm	1830 x 860 x 1560mm	505/483kgs
SF-500LA	2.5kw	AC 220V 1/3PH 50/60Hz	L+H≤530mm W+H≤430mm H≤150mm	650 X 620mm	15m/min.	6-8kg/cm2	POF	2065 X 1085 X 1600mm	2115 x 1135 x 1750mm	545/513kgs
SF-600LA	3.4kw	AC 220V 1/3PH 50/60Hz	L+H≤530mm W+H≤430mm H≤150mm	800 X 700mm	15m/min.	6-8kg/cm2	POF	2240 X 1185 X 1600mm	2290 x 1235 x 1750mm	605/583kgs
SF-4525	9kw	AC 380/220V 3PH 50/60Hz	1000 X 300 X 200mm	/	0-20m/min	/	POF	1300 X 800 X 1520mm	1580 x 770 x 1105mm	234/215kgs





技术参数 Technical Parameter

型号 Model	功率 Power	电源 Power Supply	炉腔尺寸 Tunnel Size L x W x H	最大包装尺寸 Max. Package Size	封刀长度 Blade Length	空气温度 Air Temperature	工作台高度 Table Height	包装速度 Packing Speed	外接气源 External Air Source	适用收缩膜 Shrink Film	机械尺寸 Machine Size L x W x H	包装尺寸 Package Size L x W x H	毛净重 G./N. Weight
GH-6030AZ	2kw	AC 220V 1/3PH 50/60HZ	/	300 x 500 x 300mm	670mm	0~300℃	825±50mm	15m/min.	6~8kg/cm <sup>2</sup>	PE	1628 x 1262 x 1885mm	1678 x 1312 x 2035mm	420/380kgs
GH-6030AZ	3kw	AC 220V 1/3PH 50/60HZ	/	400 x 600 x 400mm	800mm	0~300℃	825±50mm	15m/min.	6~8kg/cm <sup>2</sup>	PE	1850 x 1330 x 2066mm	1900 x 1362 x 2216mm	560/520kgs
GH-6030AZ	3.2kw	AC 220V 1/3PH 50/60HZ	/	500 x 800 x 500mm	1000mm	0~300℃	825±50mm	15m/min.	6~8kg/cm <sup>2</sup>	PE	1850 x 1530 x 2066mm	1900x 1362 x 2216mm	780/740kgs
GH-6030ZS	3kw	AC 220V 1/3PH 50/60HZ	/	300 x 500 x 300mm	670mm	0~300℃	825±50mm	15m/min.	6~8kg/cm <sup>2</sup>	PE	1850 x 1200 x 1770mm	1900 x 1250 x 1920mm	450/420kgs
SF-6040E	22kw	AC 380/220V 3PH 50/60HZ	1800 x 600 x 400mm	W500 x H300mm	/	0~300℃	825±50mm	0~15m/min.	/	PE	2800 x 950 x 1750mm	2800 x 1000 x 1900mm	625/565kgs

产品特点 Product Features

- GH-6030AZ+SF-6040E全自动直进料袖口式包装机采用独特的直线式设计，结构紧凑占地面积小，针对一些场地受限及包装过程中无需调整前进方向的产品，十分方便，不会受包装物长度的限制；
- 可独立工作，也可与生产线对接自动进料、裹膜、封切、收缩、冷却、定型来实现无人化流水作业；
- 该机引进国外先进技术及工艺制作，设备性能稳定可靠；
- 采用永宏PLC可编程程序控制器，实现机、电、气一体化；
- 经过特殊的改装后，轻及小的产品均能轻松包装；
- 该机与普通侧进料机器相比，有速度和衔接上的优势；
- 采用特别设计的封刀，封口线牢固、不开裂、不易粘刀；
- 采用进口光电，准确定位，针对产品设计二组水平检测光电；
- 原装进口输送皮带，经久耐用，传送速度由变频器控制，可无级变速；
- 人性化设计的控制箱，方便操作人员的操作；
- 封切时后端配有压料装置，对于包装较轻的物品，均不会发生移位；
- SF-6040E采用进口双运风电机，使炉腔内热风散布均匀，收缩后效果更加美观；
- 可根据客户的要求增加外侧安全防护罩；
- 采用实心钢杆外包进口硅胶管，链杆式输送硅胶经久耐用，根据包装物的不同采用不同材质的输送链；
- 整机采用进口变频器控制传送速度，无级调速；
- 单独外接的控制箱，保证电箱内的电器元件通风良好；
- 主要适用于长度较长物体或饮料、啤酒、矿泉水、易拉罐、玻璃瓶等有纸托、纸箱的集合或单一收缩包装。

- GH-6030AZ+SF-6040E Fully-auto Straight Feeding Sleeve Sealer & Shrink Tunnel adopts the unique linear design with compact structure. It is very suitable for some limited space and packing items without adjusting the forward direction. What's more, there is no length limits;
- It can work independently and also can connect with the production line to realize the unmanned assembly line with the function of auto feeding, film wrapping, sealing, shrinking, cooling and stereotypes;
- The foreign advanced technology and production process make sure stable performance;
- Fatek PLC programmable process controller makes it to achieve the mechanical, electrical and pneumatic integration;
- After a special modification, the light and small products can also be packed;
- It has advantages of speed and connection compared with the common side feeding machine;
- The sealing line is solid without cracking and anti-sticking by using special blade;
- Two groups of imported level photoelectric devices are used to accurate positioning;
- The imported conveyor belt is durable and the conveyor speed is controlled by frequency inverter;
- The user-friendly cabinet makes the operator's operation much easier;
- The pressure device equipped behind the sealing makes sure that the position is stable even for the light product during the procession;
- SF-6040E shrink tunnel adopts the imported double recycling motors; so that the hot air in the tunnel is even to have more beautiful shrink effect;
- The outside security cover can be installed according to the customer requirement;
- The chain conveyor made of solid steel covered with imported silicone tube is very durable. Besides the chain conveyor, we also have different conveyors according the products shape and material;
- The frequency inverter controls the speed of the conveyor;
- The separate control box makes sure the electrical components have good ventilation;
- This machine is mainly applied to the longer products, such as cartons or paper trays which contain drink, beer, water, cans or glass bottles collection or single shrink wrapping.



## 全自动袖口式（焊丝圆型）封切收缩包装机

GH-6030AC+SF-6040E Fully-auto Sleeve Sealer & Shrink Tunnel(For Round Wire)



### 产品特点 Product Features

- GH-6030AC + SF-6040E全自动袖口式焊丝封切收缩包装机是针对单个圆形物体而设计。此机可与生产线对接自动进料、裹膜、封切、收缩、冷却定型，实现无人化流水作业；
- GH-6030AC引进国际先进技术及工艺制作，设备性能稳定可靠，可自动计算日产量；
- 专为焊材行业设计的一套专业封切收缩设备，感应式送膜大大减少薄膜的损耗；
- 原厂奥托尼克斯数显式温控器，温度精确，可直接看到封切时的温度状态；
- 无级机械式调速装置，调整进料输送带的速度；
- 采用永宏PLC可编程程序控制器和智能触摸屏配套，实现机、电、气一体化；
- 采用特别设计的三片式封刀，封口线牢固、不开裂、不易粘刀；
- 进料输送带专为产品定做的直进式进料方式；
- SF-6040E采用进口双运风电机，让炉腔内热风散布均匀，收缩后效果更加美观；
- 输送采用变频器控制传送速度，无级调速；
- 超大风量冷却气流，产品热缩后迅速冷却定型；
- 适用于焊材行业具有防潮、防锈，延长焊材储存期等特点的单一收缩包装设备。

Shanghai Kuko Packing Machinery Co., Ltd.

GOOD PACKING GOOD SERVICES

SURFON®

- GH-6030AC + SF-6040E Fully-auto sleeve sealer and shrink tunnel is designed for a single round object. This machine can connect production line to make automatic feeding, wrapping, sealing, shrinking and cooling to achieve unmanned production;
- GH-6030AC introduces internationally advanced technology and production process. The performance is reliable and can automatically calculate the daily output;
- It is a professional sealing and shrink equipment that specifically designed for welding consumables industry. Induction film-feeding greatly reduces the waste of film;
- Original Autonics digital temperature controller with precise temperature can show the temperature status when sealing;
- Mechanical step less speed control device to adjust the speed of the feed conveyor;
- The usage of Fatek PLC and touch screen to achieve the integrations of mechanism, electricity and pneumatic;
- Using a specially designed three-piece sealing knife keeps solid sealing line, no cracking and anti-sticking;
- Feeding conveyor is customized for the wire with straight feeding;
- SF-6040E using imported double air circulation motors so that the hot air in the oven can spread more evenly to get a good shrink effect;
- The use of frequency inverter controls transmission speed which has the function of infinitive speed;
- Large amount of cooling air flow, rapidly cooling the product after hot shrinking;
- The single shrink packaging equipment is suitable of welding industry with the advantages of anti-moisture, anti-rust and extending the welding consumables storage period.

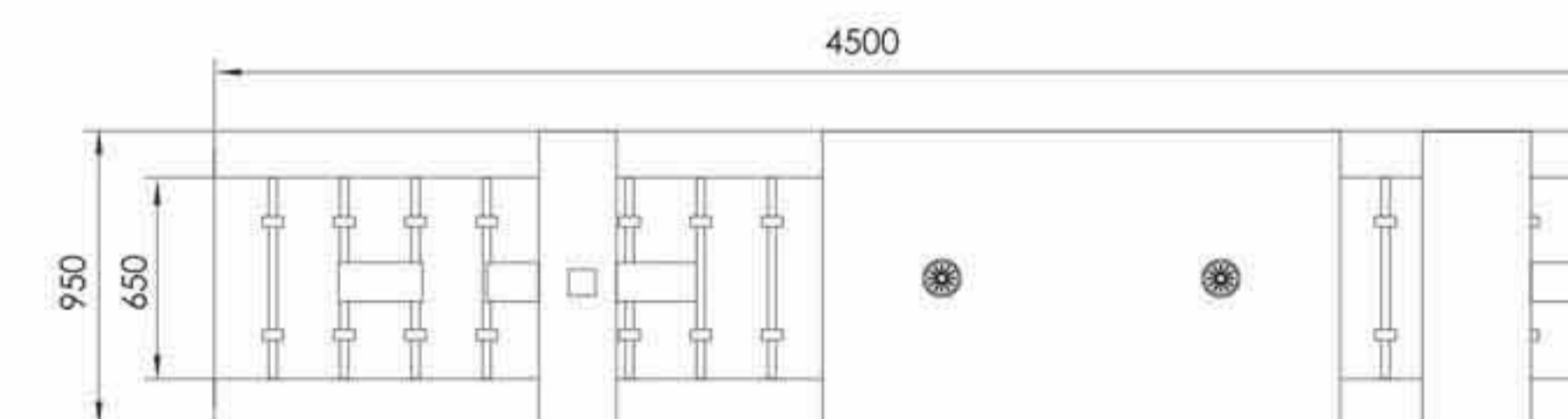
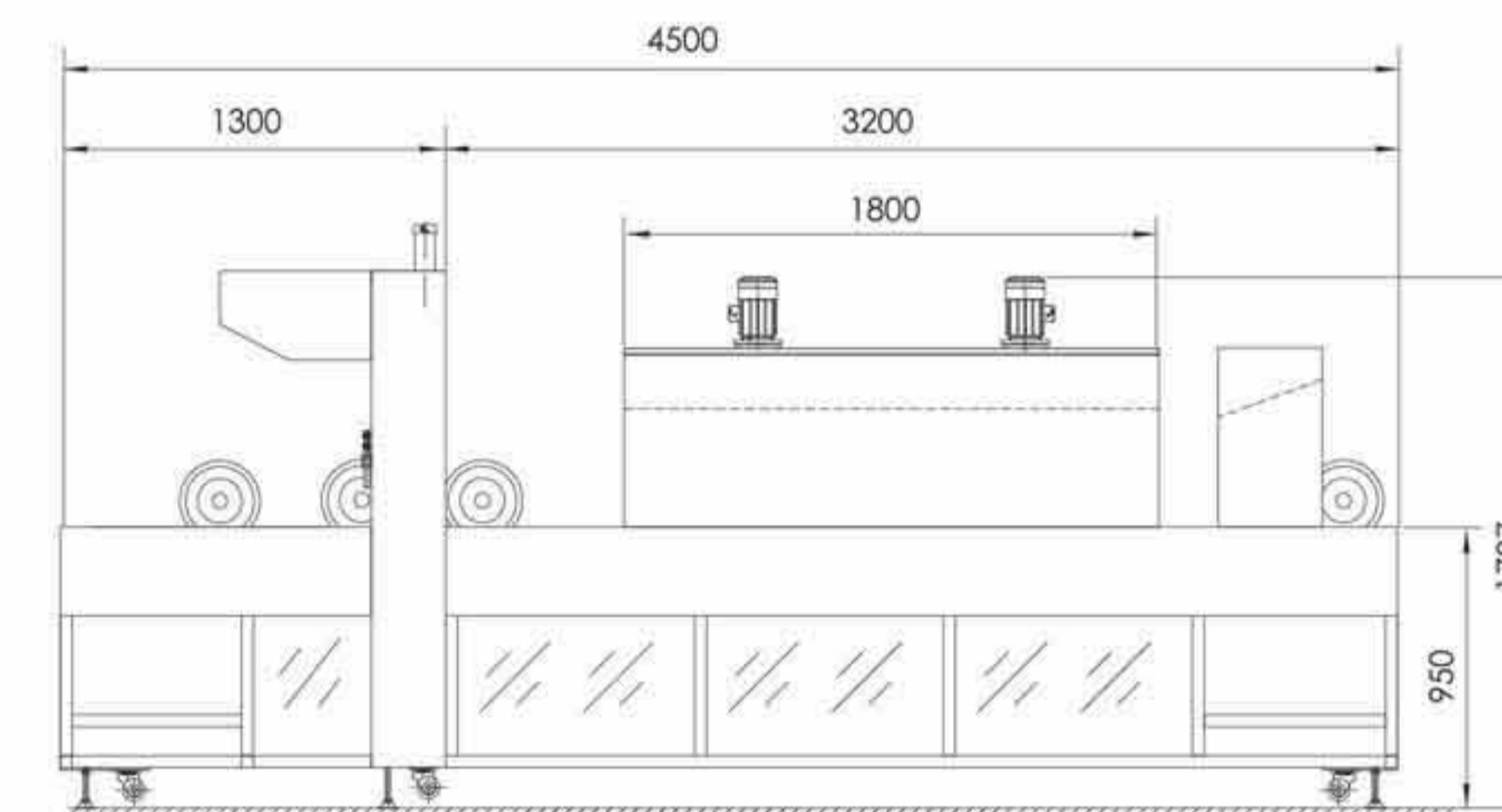

### 技术参数 Technical Parameter

型号 Model	功率 Power	电源 Power Supply	最大包装尺寸 Max. Packing Size L x W x H	炉腔尺寸 Tunnel Size W x H	封刀长度 Blade Length	空气温度 Air Temperature	工作台高度 Table Height	包装速度 Packing Speed	外接气源 External Air Source	适用收缩膜 Shrink Film	机械尺寸 Machine Size L x W x H	包装尺寸 Packaging Size L x W x H	毛净重 G./N. Weight
GH-6030AC +SF-6040E	20kw	AC 380/220V 3PH 50/60Hz	300x300x300mm	600x400mm	670mm	0~300℃	850±50mm	0~12m/min.	6~8kg/cm <sup>2</sup>	PE	4500x950x1955mm	4550x1000x2105mm	1300/1200kgs



## 全自动袖口式（整列型）封切收缩包装机

GH-6030AH+SF-6040E Fully-auto Sleeve Sealer & Shrink Tunnel (Column Type)



### 产品特点 Product Features

- GH-6030AH+SF-6040E全自动袖口式包装机是针对单个物体或无托产品而设计，此机与生产线对接后自动进料、裹膜、封切、收缩、冷却定型，是一套无需人工操作的自动化包装设备。可做到6瓶（2×3）、8瓶（2×4）、9瓶（3×3）、12瓶（3×4）、15瓶（3×5）、18瓶（3×6）、20瓶（4×5）、24瓶（4×6）等多种包装形式；
- GH-6030AH引进国际先进技术及工艺制作，设备性能稳定可靠，自动计数日产量等功能；
- 采用永宏PLC可编程程序控制器和智能触摸屏配套，实现机、电、气一体化；
- 该机可根据生产要求进行两排、三排、四排等无底托热缩包装，更换包装形式时，只需转换面板上的转换开关；
- 采用减速电机，进料输送与送膜时平稳无抖动，包装彩膜时，需增加色标定位系统，准确定位；
- 采用特别设计的封刀，封口线牢固、不开裂、不易粘刀；
- 进料输送带可根据现场的需要设计成左侧进料或右侧进料的方式；
- SF-6040E采用进口双运风电机，使炉腔内热风散布均匀，收缩后效果更加美观；
- 采用实心钢杆外包进口硅胶管，链杆输送经久耐用。亦可根据不同产品的采用不同材质的输送链；
- 采用法国施耐德变频器控制传送速度，无级调速；
- 超大风量冷却系统，产品热缩后迅速冷却定型后端可选配铝制工作台，产品包装后不会跌落地面；
- 适用于啤酒、矿泉水、易拉罐、玻璃瓶、塑料瓶类圆形产品无托等封切收缩包装。

Shanghai Kuko Packing Machinery Co., Ltd.

GOOD PACKING GOOD SERVICES

SURFON®

- GH-6030AH + SF-6040E Automatic Sleeve Sealer & Shrink Tunnel is designed for a single item or objects without tray. This machine can connect with other production machines with the function of automatically feeding, wrapping, sealing, shrinking and cooling, unmanned assembly-line to realize unmanned operation; There are many forms of packaging : 6 bottles (2 × 3), 8 bottles (2 × 4), 9 bottle (3 × 3), 12 bottles (3 × 4), 15 bottles (3 × 5), 18 bottles (3 × 6), 20 bottles (4 × 5), 24 bottles (4 × 6) etc;
- GH-6030AH introduces internationally advanced technology and production process with reliable performance and also has automatic counting daily-output functions;
- The usage of Fatek PLC and touch screen to achieve the integrations of mechanism, electricity and pneumatic;
- The machine can change the packing forms according to the production requirements, such as two rows, three rows, or four rows without tray. When replacing packaging, you just convert the switch on the panel;
- Feeding conveyor and film-feeding is smooth with gear box motors. When packaging color film, it needs to increase the color positioning system to make accurate positioning;
- A specially designed sealing knife makes sure solid sealing line, no cracking and anti-stick;
- Feeding conveyor can be designed in the left or right side as per your demands;
- SF-6040E using imported double air circulation motors, so that the hot air in the oven can spread more evenly to get a good shrink effect;
- Using solid steel rollers covered by silicone tubes which makes chain conveyor durable. We can also choose different material conveying chain according to the different products;
- The use of French Schneider frequency inverter controls transmission speed which has the function of infinitive speed;
- Large volume of wind cooling system makes products rapidly cooling after heat shrinking. We also can add outlet conveyor for your option, so that the products will not drop;
- The machine is widely used in the lines of beer, mineral water, cans, glass bottles, round bottles without tray products' shrink packaging.

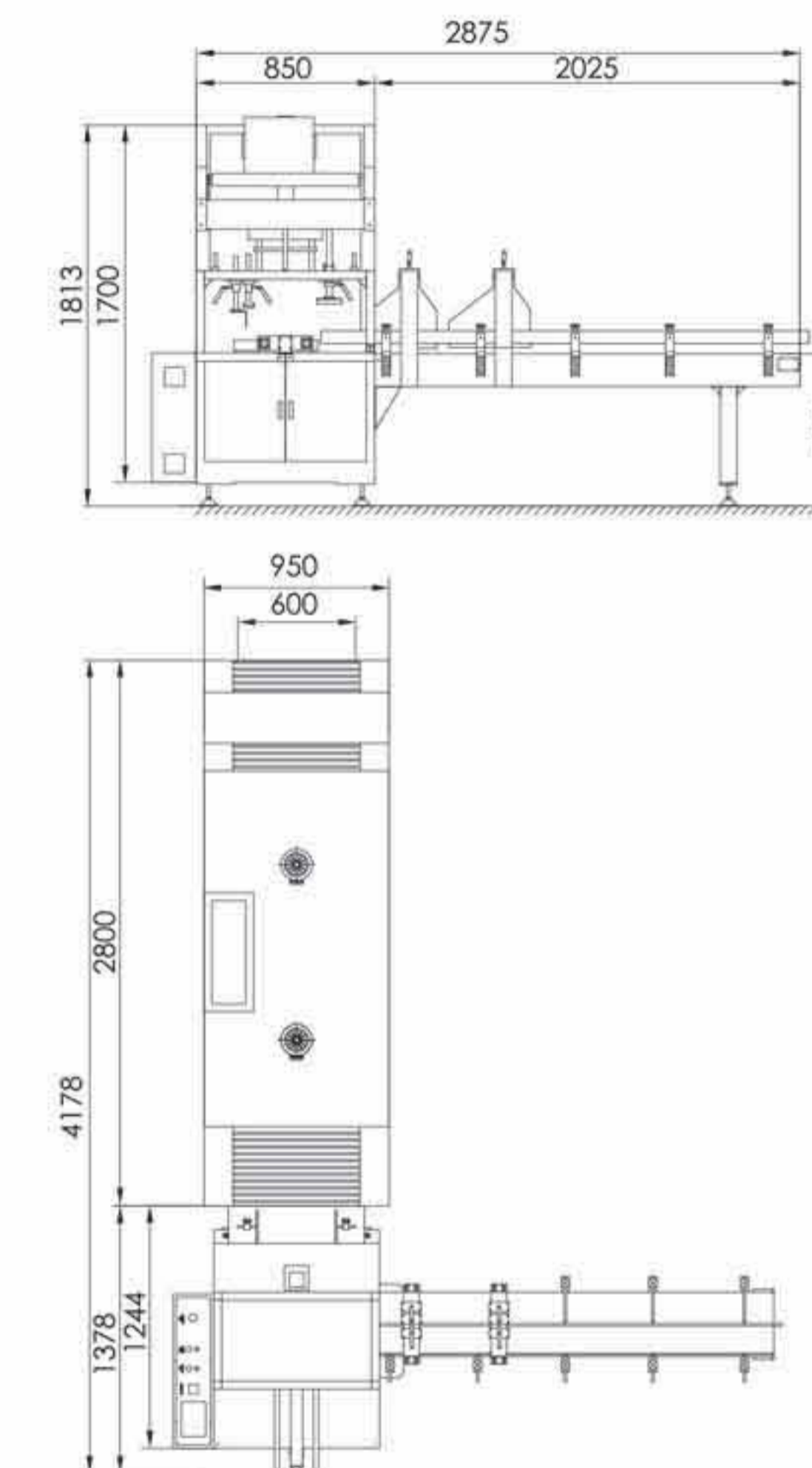

### 技术参数 Technical Parameter

型号 Model	功率 Power	电源 Power Supply	炉腔尺寸 Tunnel Size L × W × H	最大包装尺寸 Max. Packing Size L × W × H	横封刀尺寸 Sealing Blade Length	空气温度 Air Temperature	工作台高度 Table Height	包装速度 Packing Speed	外接气源 External Air Source	适用收缩膜 Shrink Film	机械尺寸 Machine Size L × W × H	包装尺寸 Package Size L × W × H	毛净重 G./N. Weight
GH-6030AH	1.8kw	AC 220V 1/3PH 50/60Hz	/	300×500×300mm	670mm	0~300℃	820±50mm	12m/min.	6~8kg/cm <sup>2</sup>	PE	2875×1378×1813mm	1428×900×1963mm 2100×455×760mm	620/520kgs
SF-6040E	18kw	AC 380/220V 3PH 50/60Hz	1800×600×400mm	1500×500×300mm	/	0~300℃	820±50mm	0~20m/min.	/	PE	2800×950×1750mm	2850×1000×1900mm	625/565kgs





产品特点 Product Features

- GH-6030A+SF-6040E全自动袖口式包装机是针对单个物体或有纸托的物品而设计，此机可与生产线对接自动进料、裹膜、封切、收缩、冷却定型，实现无人化流水作业；
- GH-6030A引进国际先进技术及工艺制作，设备性能稳定可靠，可自动计算日产量；
- 感应式送膜，大大减少薄膜的损耗；
- 原厂奥托尼克斯数显温控器，温度精确，可直接看到封切时的温度状态；
- 无级机械式调速装置，调整进料输送带的速度；
- 采用永宏PLC可编程程序控制器与智能触摸屏配套，实现机、电、气一体化；
- 采用特别设计的三片式封刀，封口线牢固、不开裂、不易粘刀；
- 进料输送带可根据需要设计成左侧进料或右侧进料的方式；
- SF-6040E采用进口双运风电机，超大风量冷却气流让炉仓内热风散布均匀，产品热缩后迅速冷却定型；
- 输送采用变频器控制传送速度，无级调速；
- 超大风量冷却气流，产品热缩后迅速冷却定型；
- 整机采用法国施耐德变频器控制传送速度，无级调速；
- 适用于饮料、啤酒、矿泉水、易拉罐、玻璃瓶有纸托、纸箱彩盒一体产品等集合或单一收缩包装。



- GH-6030A + SF-6040E Fully-auto Sleeve Sealer & Shrink Tunnel is designed for a single object or objects with paper tray. This machine can be connected with other production machines with the function of automatically feeding, wrapping, sealing, shrinking and cooling to realize unmanned operation;
- GH-6030A introduces internationally advanced technology and production process which can automatically calculate the daily output; The performance is reliable;
- Inductive film-feeding greatly reduces film waste;
- Imported Autonics digital temperature controller shows precise temperature directly when it is sealing;
- Stepless mechanical speed adjustment device regulates the speed of the feeding conveyor;
- The usage of Fatek PLC and touch screen achieves the integrations of mechanism, electricity and pneumatic;
- A specially designed three-piece sealing knife makes sure solid sealing line, no cracking and anti-stick;
- Feeding conveyor can be designed in the left or right side as per your needs;
- SF-6040E using imported double air circulation motors, so that the hot air in the oven can spread more evenly to get a good shrink effect;
- Large amount of cooling air flow, rapidly cooling the product after heat shrinking;
- The use of French Schneider frequency inverter controls transmission speed which has the function of infinitive speed;
- For drinks, beer, mineral water, cans, glass bottles with paper- tray and cardboard boxes integrated or single product's shrink-wrapping.

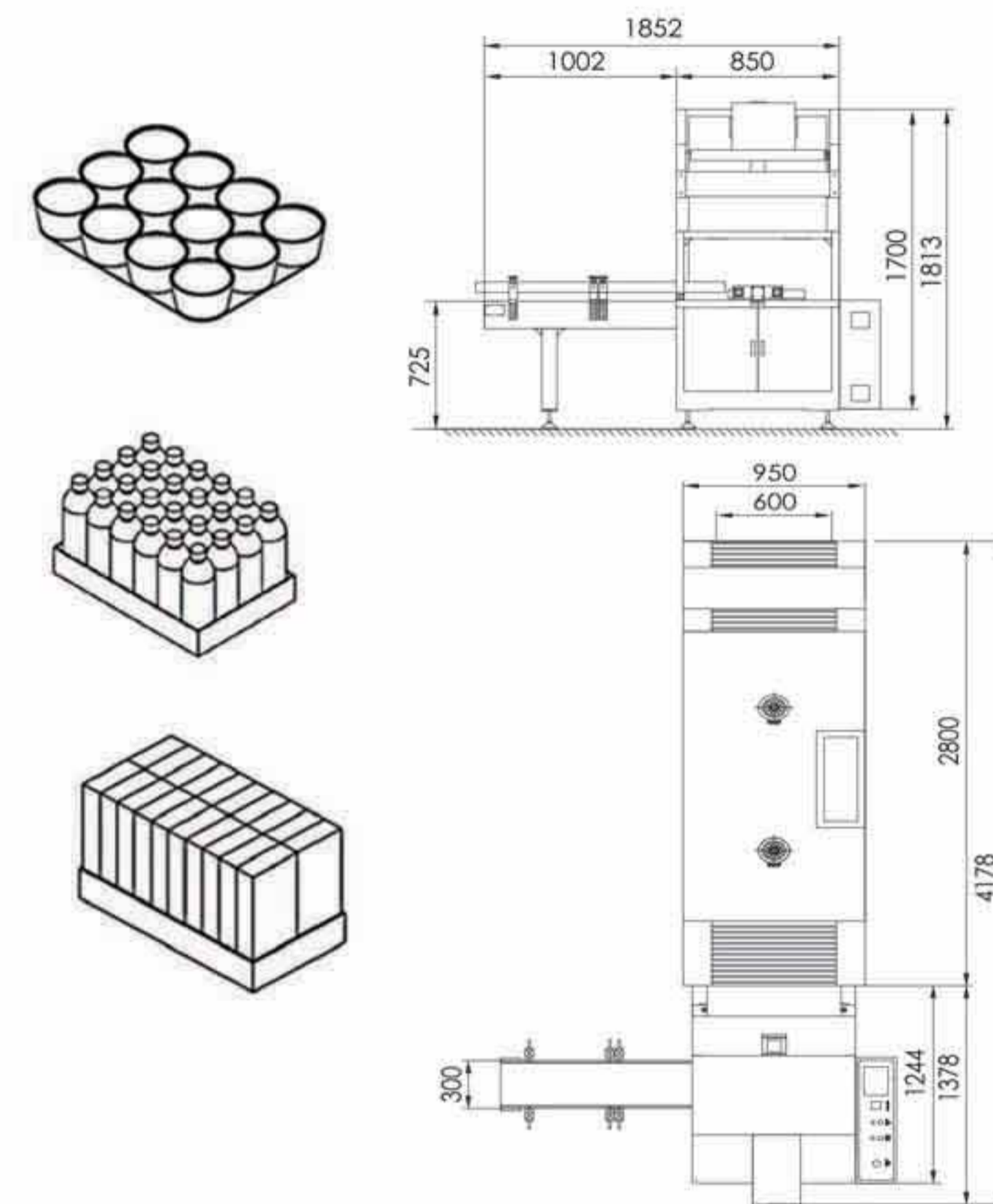

技术参数 Technical Parameter

型号 Model	功率 Power	电源 Power Supply	最大包装尺寸 Max Packing Sizes L x W x H	炉腔尺寸 Tunnel Size L x W x H	温度 Temperature	工作台高度 Table Height	包装速度 Packing Speed	外接气源 External Air Source	适用收缩膜 Shrink Film	机械尺寸 Machine Size L x W x H	包装尺寸 Packaging Size L x W x H	毛净重 G.N. Weight
GH-6030A (670mm)	1.5kw	AC380V/220V 3PH 50/60HZ	300 x 500 x 300 mm	/	0~300℃	825±25mm	0~15 m/min.	6~8kg/cm <sup>2</sup>	PE	1852 x 1378 x 1813mm	1428 x 900 x 1963mm 1850 x 350 x 450mm	480/410kgs
GH-6030A (800mm)	2.2kw	AC380V/220V 3PH 50/60HZ	400 x 600 x 400 mm	/	0~300℃	825±25mm	0~15 m/min.	6~8kg/cm <sup>2</sup>	PE	3500 x 1912 x 2080mm	2015 x 1505 x 2380mm 2600 x 1020 x 720mm	700/660kgs
GH-6030A (1000mm)	2.5kw	AC380V/220V 3PH 50/60HZ	500 x 800 x 500 mm	/	0~300℃	825±25mm	0~15 m/min.	6~8kg/cm <sup>2</sup>	PE	3000 x 1912 x 2180mm	2015 x 1505 x 2480mm 2600 x 1020 x 720mm	870/830kgs
SF-6040E	18kw	AC380V/220V 3PH 50/60HZ	1500 x 500 x 300 mm	1800 x 600 x 400 mm	0~300℃	825±25mm	0~20 m/min.	/	PE	2800 x 950 x 1750mm	2850 x 1000 x 1900mm	625/565kgs



## 全自动袖口式封切收缩包装机（多排型）

GH-5030AE+SF-5030E Fully-auto Sleeve Sealer & Shrink Tunnel (Multi-rows)



### 产品特点 Product Features

- GH-5030AE+SF-5030E适用于各类盒装品单层单排或多排数的集体无底托收缩包装，具有自动排列功能，大大提高了生产效率，产品经过包装后具有外观整洁、紧凑不散，保证物品质量及整体性运输方便；
- GH-5030AE采用国际先进的制造技术，主要为不同行业小盒类包装而设计；
- 该机可根据生产要求自动完成1排到多排的组合包装，不需要单独制作模具；
- 采用永宏PLC可编程程序控制器和智能触摸屏，实现机、电、气一体化；
- 不同的包装形式在设计好的触摸屏上即可完成，同时对生产量可进行计数；
- 采用特别设计的封刀，封口线牢固、不开裂、不易粘刀；
- 进料采用皮带式输送，速度快，运行平稳，根据需要可增加彩膜定位系统；
- 进口光电，准确定位各种设置；
- SF-5030E采用进口双运风电机，让炉腔内热风散布均匀，收缩后效果更加美观；
- 采用高温特氟龙输送方式经久耐用，输送产品稳定；
- 采用法国“施耐德”变频器控制传送速度，无级调速；
- 适用于日用品、保健品、文具等的集合热缩包装、烟草配送中心的烟条包装或其他各种形状包装物的多层多排包装。

Shanghai Kuko Packing Machinery Co., Ltd.

GOOD PACKING GOOD SERVICES

SURFON®

- GH-5030AE + SF-5030E is fit for a wide range of shrink wrapping with single or multi-rows boxes. The automatic alignment greatly improves the production efficiency. After packaging the items have a compact and neat appearance which ensures the items' quality and integrity of convenient transportation;
- GH-5030AE adopts international advanced manufacturing technology which mainly designs for small boxes wrapping of different lines;
- The machine can be automatically routed to complete a combination of single or multi rows packaging according to production requirements without separate molds;
- The usage of Fatek PLC and touch screen to achieve the integrations of mechanism, electricity and pneumatic;
- Different types of packaging can be selected on the touch screen, while the production volume can be counted;
- A specially designed blade makes sure solid sealing line, no cracking and anti-stick;
- The feeding part uses belt conveyor which is fast and smooth; as required to increase the color film positioning system;
- Using imported photo sensor to make accurate positioning of various setting;
- SF-5030E using imported double air circulation motors, so that the hot air in the oven can spread more evenly to get a good shrink effect;
- Anti-high temperature Teflon mesh conveyor is durable and keeps stable feeding;
- The use of French Schneider frequency inverter controls transmission speed which has the function of infinitive speed;
- Suitable for daily necessities, health care products, stationery and other collections of shrink wrapping, tobacco packaging, various other shapes multi-layer or multi-row packaging.

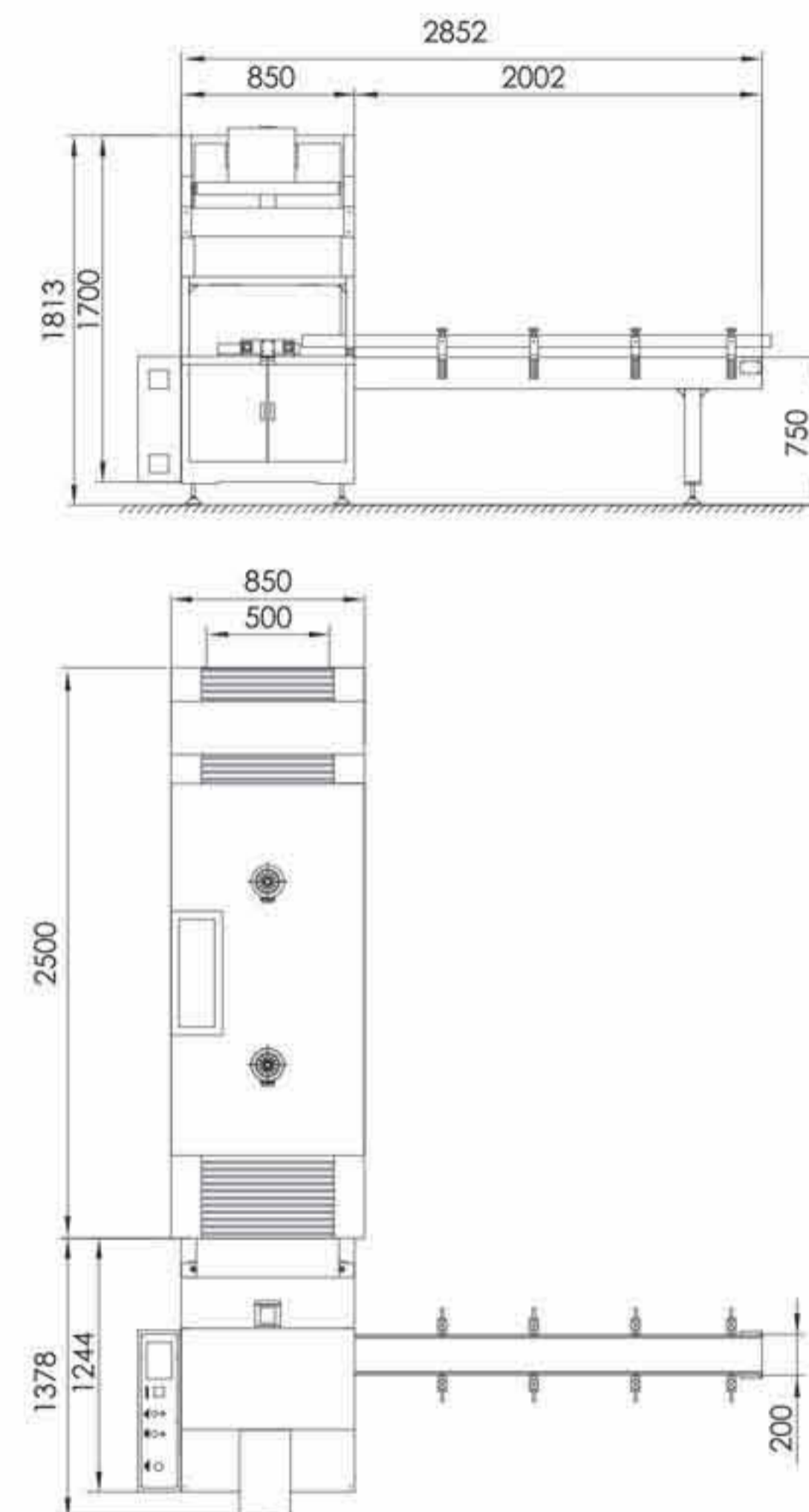

### 技术参数 Technical Parameter

型号 Model	功率 Power	电源 Power Supply	炉腔尺寸 Tunnel Size L x W x H	最大包装尺寸 Max. Packing Size L x W x H	封刀长度 Blade Length	空气温度 Air Temperature	工作台高度 Table Height	包装速度 Packing Speed	外接气源 External Air Source	适用收缩膜 Shrink Film	机械尺寸 Machine Size L x W x H	包装尺寸 Package Size L x W x H	毛净重 G./N. Weight
GH-5030AE	1.2 kw	AC 220V 1/3PH 50/60Hz	/	300 x 300 x 200mm	570mm	0~300℃	825 ± 25mm	0~12m/min.	6~8 kg/cm <sup>2</sup>	PE	2852 x 1378 x 1813mm	1428 x 900 x 1963mm 2050 x 250 x 500mm	450/390kgs
SF-5030E	16 kw	AC 380/220V 3PH 50/60Hz	1000 x 500 x 300mm	W400 x H200mm	/	0~300℃	825 ± 25mm	0~20m/min.	/	PE	1600 x 800 x 1650mm	1650 x 850 x 1800mm	405/380kgs



## 全自动袖口式封切收缩包装机（胶带类）

GH-6030AE+SF-5030E Fully-auto Sleeve Sealer & Shrink Tunnel (For Tapes)



### 产品特点 Product Features

- GH-6030AE+SF-5030E全自动袖口式包装机是针对多个胶带的包装而设计；
- 可独立工作，也可与生产线对接自动进料、裹膜、封切、收缩、冷却、定型，无人化流水作业；
- 该机引进国外先进技术及工艺制作，设备性能稳定可靠；
- 采用永宏PLC可编程程序控制器，实现机、电、气一体化；
- 不同的包装形式在设计好的触摸屏上即可完成，同时对生产量可进行计数；
- 采用特别设计的封刀，封口线牢固、不开裂、不易粘刀；
- 进料采用皮带式输送，速度快，运行平稳，根据需要可增加彩膜定位系统；
- 进口光电，准确定位各种设置；
- SF-5030E采用进口双运风电机，让炉腔内热风散布均匀，收缩后效果更加美观；
- 采用高温特氟龙输送方式经久耐用，输送产品稳定；
- 采用法国施耐德变频器控制传送速度，无级调速；
- 该机主要适用于多个胶带的组合包装。

Shanghai Kuko Packing Machinery Co., Ltd.

GOOD PACKING GOOD SERVICES

SURFON®

- GH-6030AE+SF-5030E Fully-auto Sleeve Sealer & Shrink Tunnel is designed for multiple tapes packing;
- It can work independently and also can connect with the production line to realize the unmanned assembly line with the function of auto feeding, film wrapping, sealing, shrinking, cooling and stereotypes;
- The foreign advanced technology and production process make sure the stable performance;
- Fatek PLC programmable process controller makes it achieve the mechanical, electrical and pneumatic integration;
- Different types of packaging can be selected on the touch screen, while the production volume can be counted;
- A specially designed blade makes sure solid sealing line, no cracking and anti-stick;
- The feeding part uses belt conveyor which is fast and smooth; as required to increase the color film positioning system;
- Using imported photo sensor to make accurate positioning of various setting;
- SF-5030E using imported double air circulation motors, so that the hot air in the oven can spread more evenly to get a good shrink effect;
- Anti-high temperature Teflon mesh conveyor is durable and keeps stable feeding;
- The use of French Schneider frequency inverter controls transmission speed which has the function of infinitive speed;
- This machine is applied to a groups of tapes packing.

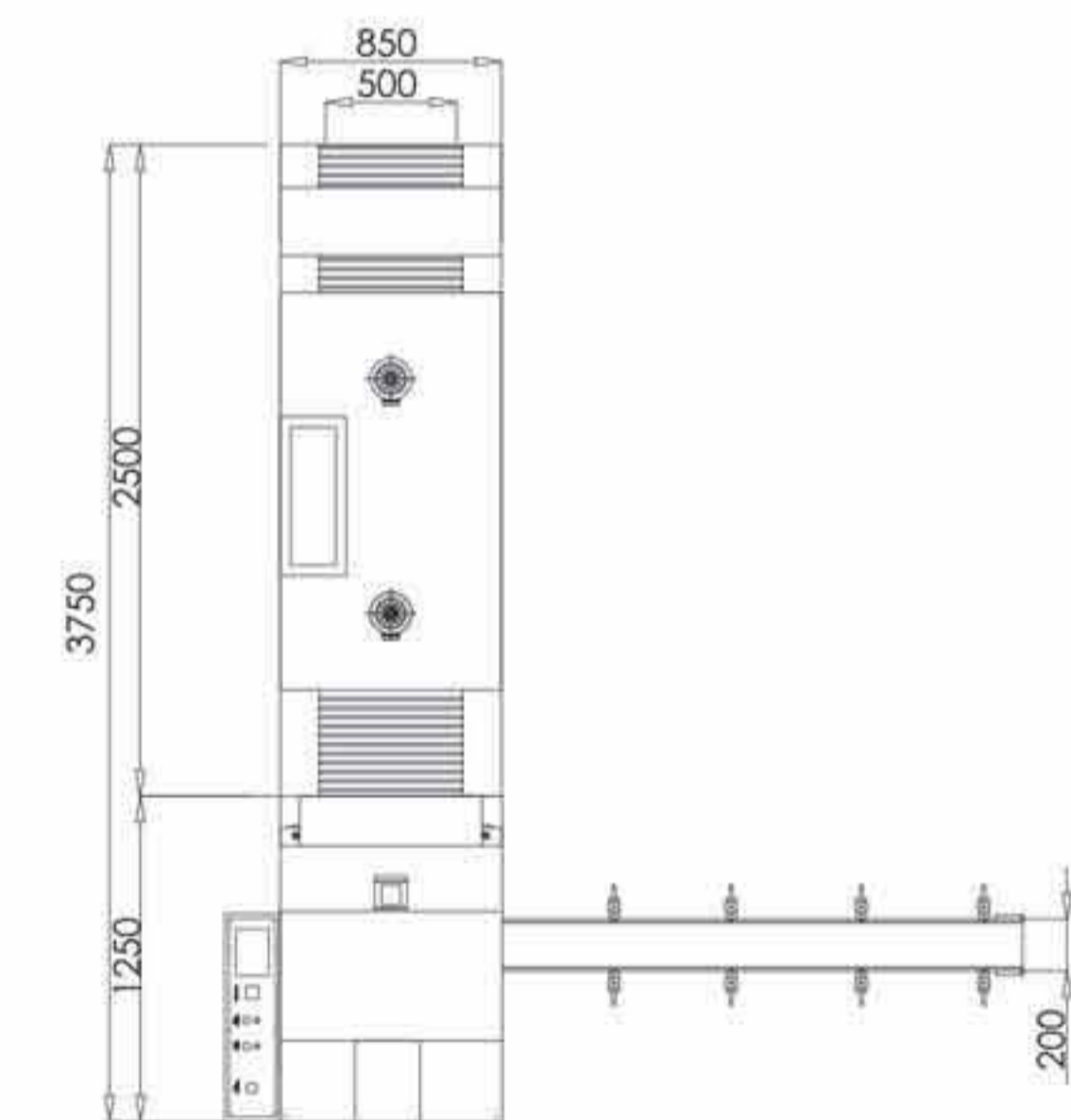
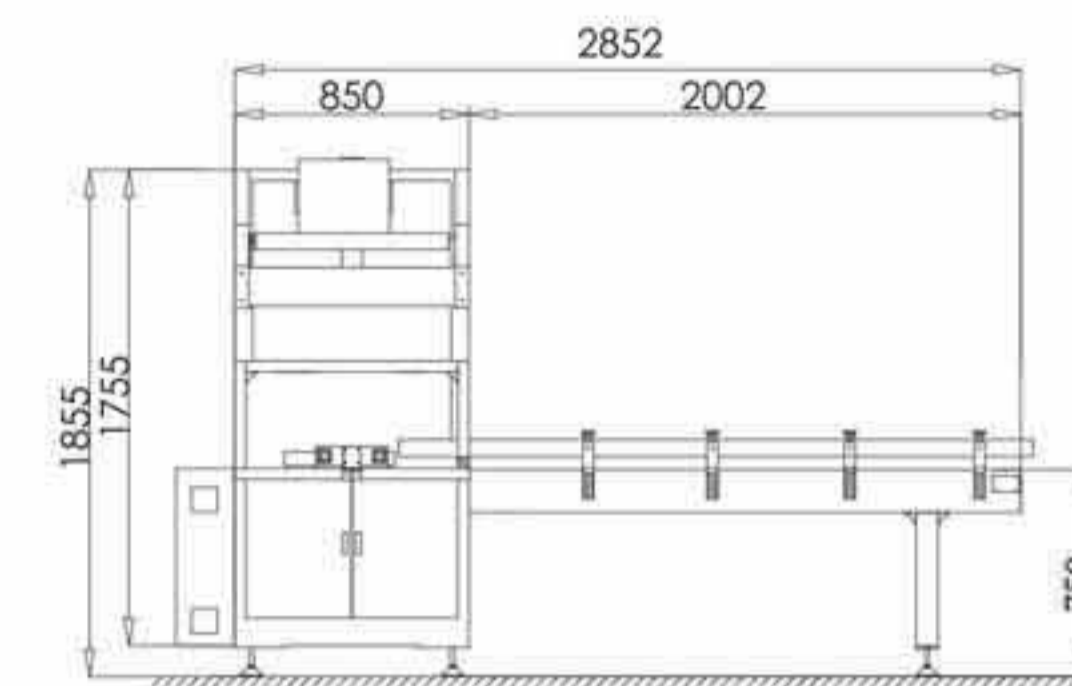

### 技术参数 Technical Parameter

型号 Model	功率 Power	电源 Power Supply	炉腔尺寸 Tunnel Size L x W x H	最大包装尺寸 Max. Packing Size	封刀长度 Blade Length	空气温度 Air Temperature	工作台高度 Table Height	包装速度 Packing Speed	外接气源 External Air Source	适用收缩膜 Shrink Film	机械尺寸 Machine Size L x W x H	包装尺寸 Package Size L x W x H	毛净重 G./N. Weight
GH-6030AE	1.5kw	AC 220/380V 1/3PH 50/60Hz	/	Φ180 x L400mm	670mm	0~300℃	825±25mm	0~12m/min.	6~8 kg/cm <sup>2</sup>	PE	1250×750×1855mm	1300×800×2005mm 2050×250×550mm	450/390kgs
SF-5030E	16 kw	AC 380/220V 3PH 50/60Hz	1500×500×300mm	1200×400×200mm	/	0~300℃	825±25mm	0~20m/min.	/	PE	2500×800×1650mm	2550×900×1800mm	500/450kgs





产品特点 Product Features

- 人民币在流通过程中，银行需对纸币进行回笼、清分、包装、入库等管理。清分完成的纸币以一定数额张数进行捆扎成把，再以一定把数的纸币打包成捆，整个过程中，传统人工操作方式效率低，且可能会进一步损坏纸币。为此，推出了采用热收缩膜塑封打包的方式捆扎纸币，该方式提高了纸币打包效率，并对纸币起到一定的保护作用。
  - 基于二维码技术的批号系统；
  - 这款机器适用于银行钱币、钞票和票据的收缩包装；机身小巧使的对操作场地没有限制；
  - 采用特氟龙涂层处理的封刀，耐高温，不粘刀；
  - 采用先进的西门子PLC和触摸屏保证了精确的动作；
  - 热风循环收缩炉采用不锈钢加热管，大大延长机器的使用寿命，收缩温度及输送速度均可调节；
  - 废膜收卷系统创造了干净和安全的生产环境；
- Currency in the circulation process, the bank required return, clearing, packaging, storage and management of banknotes. By strapping into the clearing notes to a certain amount of sheets, and then to a certain number of banknotes packaged into bundles in the whole process, the traditional manual mode of operation efficiency is low, and may further damage the notes. For that reason, the introduction of a thermal contraction film packaging plastic way to bundle banknotes, which improves the efficiency of paper packaging, and paper money plays a certain role in the protection.
  - The system of Batch number based on two-dimensional code technology
  - The machine is suitable for bank money, banknotes and bank bills shrink wrap. The sizes of this machine is small which makes it is very suitable for packing operations in the limited space.
  - The blade with Teflon treatment can endure high temperature without sticking; Sealing and cutting system with constant temperature makes the sealing straight, firm and beautiful;
  - The machine applies the most advanced Siemens PLC accompanied with touch screen guarantee the precise action;
  - Hot air circulating shrink tunnel uses stainless steel heating elements which could ensure long life span; the shrinking temperature and conveyor speed are adjustable;
  - Waste film recycling system creates a clean and safe production atmosphere;

技术参数 Technical Parameter

型号 Model	功率 Power	电源 Power Supply	横封刀长度 Sealing Blade Length	工作台高度 Table Height	包装速度 Packing Speed	适用收缩膜 Shrink Film	捆扎带 Strapping tape	机械尺寸 Machine Size L x W x H
GH-3020BM	3 kw	AC 220V 1/3 PH 50/60HZ	204mm	817mm	5-8 pcs/min	POF	PE	1375 x 800 x 1673mm

切角机



产品特点 Product Features

- 结合先进的瞬间封口技术，经过改良并独特设计制造，封口牢固，不起皱；
  - 采用韩国进口加热丝；使用寿命长，能效高；
  - 开关、变压器等主要电气零件均采用品牌部件，工作稳定，故障率低；
  - 机架和工作台面采用铝合金整板加工，整机无焊接点
  - 整机操作简单，方便，实用；封口线可调，同时可以切掉产品拐角的废膜；
  - 包装后外型美观，具有防尘，防潮，防破损的作用。提高了产品附加值且节约包装成本。
  - 本机适用于PVC, POF, PET收缩膜；
  - 本机广泛应用于食品、电子、玩具、五金、化妆品、药品、日用品、书籍、电器等产品的外包装。
- Combined with the advanced instant sealing technology, it has been improved and designed uniquely. It has firm sealing and no wrinkling;
  - Adopting imported heating wire from Korea, with long service life and high energy efficiency;
  - Switches, transformers and other major electrical parts are brand components, stable work, low failure rate;
  - The frame and worktable is made of aluminum alloy plate, and the whole machine has no welding point;
  - The whole machine is simple, convenient and practical; the sealing line can be adjusted, and the waste film on the corner of the product can be cut off at the same time;
  - After packing, it has beautiful appearance, dustproof, moisture-proof and anti breakage. Increase the added value of products and save the cost of packaging.
  - This machine is suitable for PVC, POF, PET shrink film;
  - This machine is widely used in food, electronics, toys, hardware, cosmetics, pharmaceuticals, daily necessities, books, electrical appliances and other products' packaging.

技术参数 Technical Parameter

型号 Model	功率 Power	电源 Power Supply	最大包装尺寸 Max Packing Sizes L x W x H	横封刀长度 Sealing Blade Length	外接气源 External Air Source	适用收缩膜 Shrink Film	机械尺寸 Machine Size L x W x H	包装尺寸 Packaging Size L x W x H	毛净重 G.N. Weight
SF-400C	2.5kw	AC 220V 1/3PH 50/60HZ	W + H < 580, Max. Corner cutting size: W + H < 380mm	400mm	6-8kg/cm <sup>2</sup>	POF	570 x 525 x 750mm	620 x 575 x 850mm	85/75kgs
SF-600C	3.5kw	AC 220V 1/3PH 50/60HZ	W + H < 780, Max. Corner cutting size: W + H < 380mm	600mm	6-8kg/cm <sup>2</sup>	POF	750 x 528 x 878mm	800 x 578 x 928mm	115/105kgs





产品特点 Product Features

- GH-6030 采用原装进口电机，使推料和封切时更加平稳；
- 采用特别设计的封刀，封口线牢固、不开裂且不易粘刀；
- 使用原装进口电气元件，减少了使用过程中的故障；
- 隐蔽式的电机装置，大大增加操作的方便性。后端的压料装置，保证包装轻的物品时不会发生移位；
- 可以包装不同形状规格的产品，前端的定位框架可任意调整；
- SF-6040E采用双运风电机，炉腔内热风量均匀，收缩后效果美观；
- 采用实心钢杆外包进口硅胶管，链杆式输送，硅胶经久耐用，其中SF-6040E可添加密轴功能，专为包装体积比较小的产品而设计；
- 输送采用变频器控制传送速度，无级调速；
- GH-6030+SF-6040E是GH系列袖口式包装机中的一款经济型机器。该机操作简单，轻触推料按钮，机器自动封切进入收缩包装机，主要采用PE收缩薄膜；
- 适用于饮料、日化、建材、食品等有纸托或无纸托的集合包装，也可用于电器、汽车零件、家私、地板等单个或多个组合的封切热缩包装。

- GH-6030 using imported motor makes it more stable during pushing and sealing;
- A specially designed sealing knife makes sure solid sealing line, no cracking and anti-stick;
- Usage of imported electrical components reduces failure during the using process;
- Concealed motor device greatly increases the convenience of operation. Back end pressing device ensures that the light products will not move;
- The front fixing frame can be adjusted, so it can pack different shapes products;
- SF-6040E using imported double air circulation motors, so that the hot air in the oven can spread more evenly to get a good shrink effect;
- Using solid steel rod covered by imported silicone tubes, chain conveying, durable silicone; SF-6040E can add density axis function which specially designed for small volume products;
- The use of frequency inverter controls transmission speed which has the function of infinitive speed;
- GH-6030 + SF-6040E is an economical machine in GH Series sleeve shrink packaging machine. The operation is simple. Just pressing the pusher button, the machine automatically seal then the products enter into shrink packaging machine. The machine mainly uses PE shrink film;
- The machine is widely used in drinks, daily chemical, building materials, food with paper tray or without paper tray etc. And it also can be used for electrical appliances, auto parts, furniture, flooring and other individual or group shrink wrap.

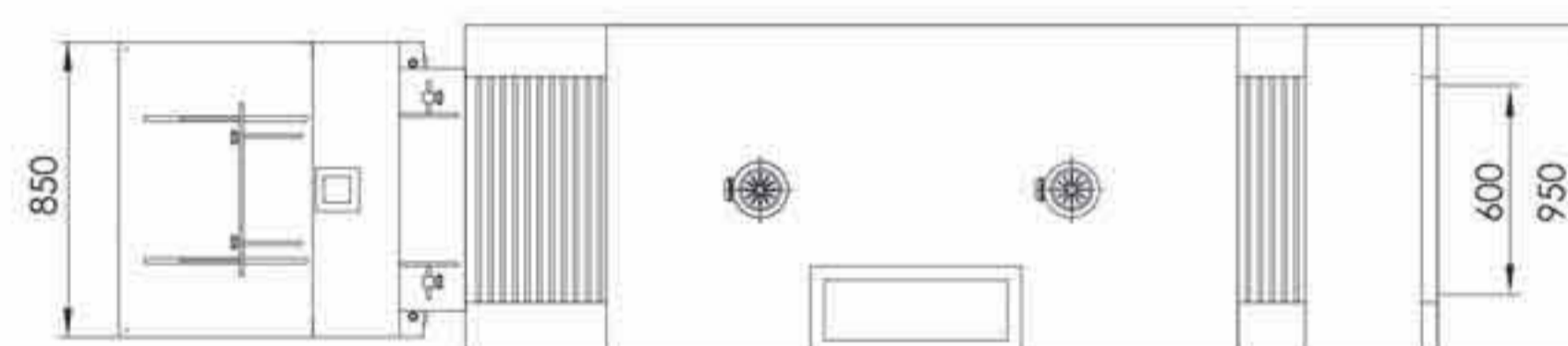
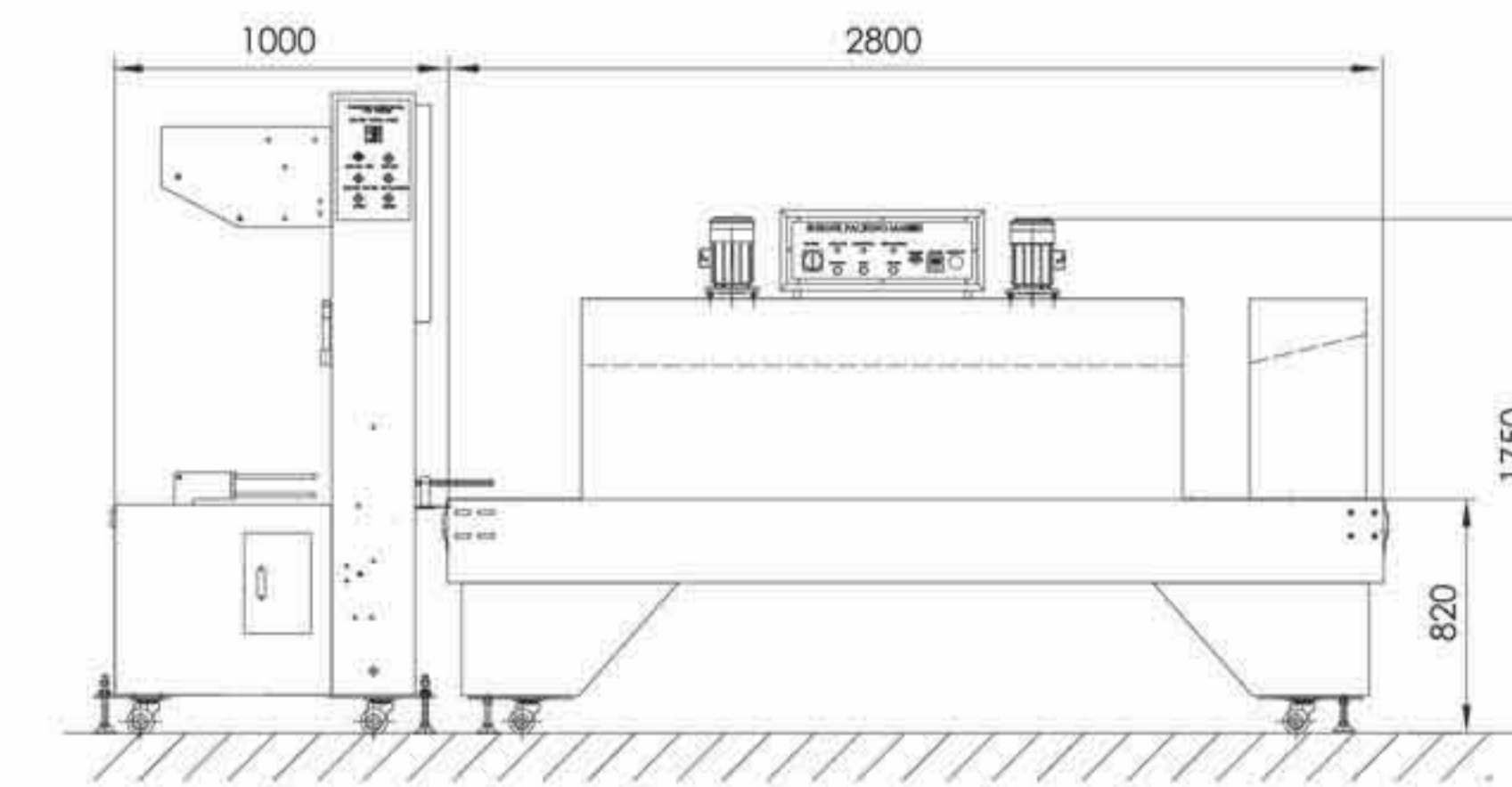

技术参数 Technical Parameter

型号 Model	功率 Power	电源 Power Supply	炉腔尺寸 Tunnel Size L x W x H	最大包装尺寸 Max. Packing Size L x W x H	空气温度 Air Temperature	工作台高度 Table Height	包装速度 Packing Speed	外接气源 External Air Source	适用收缩膜 Shrink Film	机械尺寸 Machine Size L x W x H	包装尺寸 Package Size L x W x H	毛净重 G./N. Weight
GH-6030 (670mm)	1.8kw	AC 220V 1/3PH 50/60Hz	/	300 x 500 x 300mm	0~300℃	825±25mm	5~8m/min.	6~8kg/cm <sup>2</sup>	PE	1135 x 850 x 2045mm	1185 x 900 x 2195mm	235/215kgs
GH-6030 (800mm)	2.3kw	AC 220V 1/3PH 50/60Hz	/	500 x 600 x 300mm	0~300℃	825±25mm	5~8m/min.	6~8kg/cm <sup>2</sup>	PE	1330 x 1150 x 2045mm	1380 x 1200 x 2195mm	364/340kgs
GH-6030 (1000mm)	2.7kw	AC 220V 1/3PH 50/60Hz	/	500 x 800 x 300mm	0~300℃	825±25mm	5~8m/min.	6~8kg/cm <sup>2</sup>	PE	1500 x 1350 x 2045mm	1550 x 1400 x 2195mm	476/450kgs
SF-6040E	18kw	AC 380/220V 3PH 50/60Hz	1800x600x400mm	1500x500x300mm	0~300℃	825±25mm	0~15m/min.	/	PE	2800x950x1750mm	2850x1000x1900mm	625/565kgs



SF-20LG+SF-4525 (Semi-auto L Bar Sealer & Shrink Tunnel)

产品特点 Product Features

- 本套设备由热收缩机和封切机两个部分组成。采用“L”型人工封切，然后自动传输进收缩机室，完成收缩过程；
- 抗粘耐高温合金“L”型封刀，封口整齐不开裂，不焦化，不冒烟，镀特弗龙不粘层封刀，封切不粘膜；
- 手动摇轮便于调节输送带高低；
- 通过时间继电器精确控制封切时间；
- 滑动式胶膜支架可放置各种规格收缩膜，打孔装置顺滑；
- SF-20LG/B整套封切动作由气缸自动完成，大大减少工作强度并提高生产效率；
- 封刀带自动防误切、防过热保护装置，有效防止误切包装物，保护操作者安全；
- This machine is made of shrink tunnel and sealing machine. Adopt L bar sealing, then automatically transit to the shrink chamber and finish the shrinking;
- Anti-stick high-temperature alloys L type sealing knife which can seal neatly, without cracking, coking and smoking; The sealing blade with Teflon non-stick coating layer makes shift non-sticking.
- It is easy to adjust the conveyor height by the hand wheel;
- Control the sealing time by time relay;
- Sliding bracket can be placed all kinds of shrink film, while the punching device is smooth;
- The whole sealing function of SF-20LG/B is automatically completed by cylinder which decreases labor intensity and increases working efficiency;
- Sealing knife with automatic anti mistakenly cutting and anti-overheating protection device effectively protect the operator away from accidental cutting;



技术参数 Technical Parameter

型号 Model	功率 Power	电源 Power Supply	炉腔尺寸 Tunnel Size L x W x H	最大包装尺寸 Max. Packing Size L x W x H	最大承载量 Max. Loading Weight	适用收缩膜 Shrink Film	工作台高度 Table Height	包装速度 Packing Speed	机械尺寸 Machine Size L x W x H	包装尺寸 Package Size L x W x H	毛净重 G./N. Weight
SF-20LG	1kw	AC 220V 1/3PH 50/60Hz	/	L+H≤530mm W+H≤430mm H≤200mm	25kgs	POF, PVC	750±25mm	0~15m/min.	1730 x 790 x 980 mm	1780 x 820 x 1120 mm	145/125kgs
SF-20LG/B	1kw	AC 220V 1/3PH 50/60Hz	Air Source 6-8kg/cm <sup>2</sup>	L+H≤530mm W+H≤430mm H≤200mm	25kgs	POF, PVC	750±25mm	0~15m/min.	1730 x 790 x 980 mm	1780 x 820 x 1120 mm	145/125kgs
SF-30LG	2.6KW	AC 220V 1/3PH 50/60Hz	/	L+H≤650mm W+H≤550mm H≤200mm	25kgs	POF, PVC	750±25mm	0~15m/min.	1768 x 1030 x 980 mm	1818 x 1080 x 1130 mm	190/160kgs
SF-50LG	3.8KW	AC 220V 1/3PH 50/60Hz	/	L+H≤900mm W+H≤700mm H≤300mm	30kgs	POF, PVC	750±25mm	0~15m/min.	2855 x 1220 x 1055 mm	2905 x 1270 x 1205 mm	359/329kgs
SF-60LG	4.2KW	AC 220V 1/3PH 50/60Hz	/	L+H≤1100mm W+H≤800mm H≤300mm	35kgs	POF, PVC	750±25mm	0~15m/min.	2655 x 1310 x 1890 mm	2705 x 1360 x 2040 mm	580/550kgs
SF-4525	9kw	AC 380/220V 3PH 50/60Hz	1000 x 450 x 250mm	1000 x 300 x 200mm	25kgs	POF, PVC	825±25mm	0~10m/min.	1300 x 800 x 1520 mm	1580 x 770 x 1105 mm	235/215kgs

二合一封切收缩包装机

SF-5540 (2 in 1 Shrink Wrapping Machine)

产品特点 Product Features

- This 2 in 1 shrink wrapping machine fits for packing boxes, toys, electronic bricks and so on. It can pack the products with a layer of plastic film, which makes the packaging more beautiful and firm.
- Sealing and shrinking in one station can reduce electricity consumption
- The machine is easy to handle and only one operator is required.
- The machine is economical for low volume production.
- It can monitor the shrinking operation through the transparent cover.
- 二合一收缩包装收缩机适用于包装盒，玩具，电子积木等。它可用将产品用一层塑料薄膜，使包装更加美观，牢固。
- 密封收缩可用减少电力消耗；
- 机器操作简单，仅需一名操作人员；
- 机器适用于小批量生产；
- 可以通过透明的盖子监视收缩过程。



技术参数 Technical Parameter

型号 Model	功率 Power	电源 Power Supply	Sealing Dimension	包装速度 Packing Speed	适用收缩膜 Shrink Film	机械尺寸 Machine Size L x W x H	包装尺寸 Package Size L x W x H	毛净重 G./N. Weight
SF-5540	3.8 KW	220V 1/3PH 50/60HZ	550x400mm	3~5pcs/min	PVC, POF	1765 x 850 x 1145 mm	1900 x 900 x 1110 mm	189/174kgs
SF-4255	3.6 KW	220V 1/3PH 50/60HZ	550x420mm	3~5pcs/min	PVC, POF	1265 x 750 x 1235 mm	1150 x 690 x 835 mm	159/144kgs
SF-3246	3.2 KW	220V 1/3PH 50/60HZ	460x320mm	3~5pcs/min	PVC, POF	1150 x 690 x 1200 mm	1150 x 690 x 800 mm	129/114kgs



## 高档热收缩包装机

High Grade Shrink Tunnel

SF-4020G



SF-5030LG



SF-4525



### 产品特点 Product Features

- 不锈钢加热管使用寿命长，能效高；
- 精品收缩炉采用进口施耐德变频器无级调速，调速性能稳定；标准收缩炉采用电子调速。
- 进口隔热帘布，极大地减少了热量损耗；
- The heating elements are stainless steel which has a long life span and high energy efficiency;
- Premium shrink tunnel use French Schneider inverter controls transmission speed which has the function of infinitive speed, and Standard shrink tunnel use electronic speed controls.
- Imported insulation curtain greatly reduces the heat loss;

### 技术参数 Technical Parameter

型号 Model	功率 Power	电源 Power Supply	炉腔尺寸 Tunnel Size L x W x H	空气温度 Air Temperature	工作台高度 Table Height	包装速度 Packing Speed	适用收缩膜 Shrink Film	机械尺寸 Machine Size L x W x H	包装尺寸 Package Size L x W x H	毛净重 G./N. Weight
SF-4020G	10.8kw	AC 380/220V 3PH 50/60Hz	1150 x 400 x 200mm	0~300°C	750±25mm	0~15m/min.	POF	1620 x 865 x 1090mm	1670 x 915 x 1240mm	400/370kgs
SF-5030LG	16kw	AC 380/220V 3PH 50/60Hz	1500 x 500 x 300mm	0~300°C	825±25mm	0~15m/min.	POF	1865 x 985 x 1265mm	1915 x 1035 x 1415mm	482/453kgs
SF-8030LG	21kw	AC 380/220V 3PH 50/60Hz	1800 x 800 x 300mm	0~300°C	825±25mm	0~15m/min.	POF	2165 x 1285 x 1265mm	2215 x 1335 x 1415mm	719/686kgs
SF-4525	9kw	AC380V/220V 3PH 50/60HZ	1000 x 450 x 250mm	0~300°C	750±25mm	0~15m/min.	POF	1300 x 680 x 1500mm	1580 x 770 x 1105mm	215/234kgs
SF-5030	12kw	AC380V/220V 3PH 50/60HZ	1300 x 500 x 300mm	0~300°C	750±25mm	0~15m/min.	POF	1600 x 774 x 1580mm	1850 x 810 x 1170mm	345/325kgs

Shanghai Kuko Packing Machinery Co., Ltd.

GOOD PACKING GOOD SERVICES

SURFON®

## 标签收缩包装机

SF-1230 Label Shrink Tunnel



SF-1230R 半自动标签热收缩包装机  
Semi-auto Label Shrink Tunnel



### 产品特点 Product Features

- 专为各类瓶型，杯型独特设计，收缩后标签光滑均匀，不变形；
- 进口元器件，保证了设备的稳定性；
- 本系列机型采用热风循环收缩系统，主要是针对瓶状，罐状，桶状，杯状等产品的标签收缩，同时也可以收缩瓶身，瓶底或瓶口；
- 适用于食品，饮料，药品，化妆品，农药等行业的玻璃瓶，塑料瓶，纸杯等容器套标后的瓶身或杯身标签热收缩。

- This machine is an unique design for all kinds of bottles and cups. The label will be smooth without deformation after shrinking;
- Imported components which makes sure the stability of the equipment;
- These series of models use hot air circulation shrink systems, mainly for shrink label bottle-shaped, jars, cups etc. But also can shrink the bottle neck or mouth;
- It is widely used in the bottle or cup body of beverages, pharmaceuticals, cosmetics, pesticides and other industries glass bottles, plastic bottles, cups and other containers.

### 技术参数 Technical Parameter

型号	功率 Power	电源 Power Supply	炉腔尺寸 Tunnel Size L x W x H	最大包装尺寸 Max. Packing Size L x W x H	包装速度 Packing Speed	适用收缩膜 Shrink Film	机械尺寸 Machine Size L x W x H	包装尺寸 Package Size L x W x H	毛净重 G./N. Weight
SF-1230	12kw	AC 380/220V 3PH 50/60Hz	1500 x 120 x 300mm	Φ100 x 280mm	20~40m/min.	PVC/PET	1500 x 850 x 1516mm	1550 x 900 x 1666mm	270/240kgs
SF-2040	15kw	AC 380/220V 3PH 50/60Hz	1500 x 250 x 400mm	Φ200 x 400mm	20~40m/min.	PVC/PET	1500 x 980 x 1616mm	1550 x 1030 x 1766mm	300/270kgs
SF-1230R	12kw	AC 380/220V 3PH 50/60Hz	1250 x 200 x 400mm	Φ120 x 300mm	20~40m/min.	PVC/PET	2550 x 440 x 1400mm	2600 x 600 x 1550mm	290/260kgs
SF-2040R	15kw	AC 380/220V 3PH 50/60Hz	1250 x 250 x 400mm	Φ200 x 400mm	20~40m/min.	PVC/PET	2640 x 500 x 1400mm	2700 x 620 x 1500mm	320/390kgs





### 产品特点 Product Features

- SF-6040E采用双运风电机，炉腔内热风量均匀，收缩后效果美观；
  - 采用实心钢杆外包进口硅胶管，链杆式输送，硅胶经久耐用，其中SF-6040E可添加密轴功能，专为包装体积比较小的产品而设计；
  - 输送采用法国施耐德变频器控制传送速度，无级调速；
  - 炉身长度短，可大大减小整机功率，同时保证良好的包装效果；
  - 该机操作简单，主要适用PE收缩薄膜；
  - 适用于饮料、日化、建材、食品等有纸托或无纸托的集合包装，也可用于电器、汽车零件、家私、地板等单个或多个组合的封切、热缩包装。
- SF-6040E using imported double air circulation motors, so that the hot air in the oven can spread more evenly to get a good shrink effect;
  - Chain bar conveying, using solid steel covered with durable imported silicone tube. SF-6040E can add density bar roller function which specially designed for small product;
  - The use of French Schneider inverter controls transmission speed which has the function of infinitive speed;
  - The chamber length is short which can greatly reduce the machine power; at same time it maintains good packing effect;
  - Film use: PVC, POF, PE;
  - For beverage, chemical, building material, food packing with or without tray. And the tunnel can also be used for electrical appliances, auto parts, furniture, flooring and other individual or group sealing and shrink wrap.

### 技术参数 Technical Parameter

型号 Model	功率 Power	电源 Power Supply	炉腔尺寸 Tunnel Size L x W x H	最大包装尺寸 Max. Package Size L x W x H	空气温度 Air Temperature	工作台高度 Table Height	包装速度 Packing Speed	适用收缩膜 Shrink Film	机械尺寸 Machine Size L x W x H	包装尺寸 Package Size L x W x H	毛净重 G./N. Weight
SF-6040E	22kw	AC 380/220V 3PH 50/60Hz	1800 x 600 x 400mm	1500 x 500 x 300mm	0~300℃	825 ± 25mm	0~15m/min.	PE	2800 x 950 x 1750mm	2850 x 1000 x 1900mm	625/565kgs
SF-8040E	22kw	AC 380/220V 3PH 50/60Hz	1800 x 800 x 400mm	1500 x 800 x 400mm	0~300℃	825 ± 25mm	0~15m/min.	PE	2800 x 1180 x 1750mm	2900 x 1350 x 1840mm	890/840kgs

### SF-TP 自动托盘收缩包装机

#### Automatic Pallet Shrink Packaging Machine

### 产品特点 Product Features

- 本机是采用收缩膜包在包装物品外面。经加热，使收缩膜收缩而紧贴于被包装物表面，充分显示物品的外观，以增加美观及价值感。同时包装后的物品能达到密封、防潮、防污染、防破损、防盗之目的；
  - 适用于多种物品的组合与托盘包装；
  - 本产品广泛用于大型产品托盘热收缩包装。整托包装物可配套防辐射PE热收缩膜，保护产品的光泽度及防水防尘防潮更可防氧化和光化；
  - 托盘热收缩主要代替了缠绕包装机更有美观性，整体性。运输更安全；
  - 本机可独立使用，裹包物品的输送、加热、贴体、冷却一次完成之功能。采用自动控温，热风循环、节电高效。本机速度可调，运行速度稳定，配有强力冷却系统；
  - 本机设计先进、性能稳定可靠、收缩效果好、结构新颖美观；
  - 操作维修方便等特点，可适用于多种收缩薄膜的连续收缩包装。
- This machine is used in the shrink-wrap packaging materials outside. After heating, the shrink film contracts and get close to the surface of the packaging which fully demonstrates the appearance to increase the aesthetic value and sense. Meanwhile packaged goods can reach the purpose of sealed, moisture proof, pollution prevention, anti-breakage and theft;
  - It is also used for a variety of combinations and pallet packaging;
  - It is widely adopted in large-scale product pallet. The entire package can match with anti-radiation PE shrink film, which can protect the gloss and water & dust-proof but also photochemical oxidation;
  - The pallet shrink wrapping machine is main to instead of stretch wrapper with the advantages—more aesthetics, integrity and easy transportation;
  - This machine can be used independently with the function of wrapping goods transportation, heating, fitted, and cooling completed in one time. It adopts automatic temperature control, hot air circulation, energy-saving and efficient. The speed is adjustable and stability equipped with a powerful cooling system;
  - It has advanced design, reliable performance, good contraction effect, beautiful & new structure;
  - Operation and maintenance are convenient, suitable for a variety of continuous shrink film packaging.



型号 Model	SF-TP
功率 Power	90kw
电源 Power Supply	AC 380/220V 3PH 50/60Hz
包装速度 Packing Speed	0~5m/min.
载重 Load weight	2000kgs
适用收缩膜 Shrink Film	PE
最大包装尺寸 Max. Packing SIZE L x W x H	5000 x 1000 x 1200mm
机械尺寸 Machine Size L x W x H	6000 x 1180 x 1380mm
包装尺寸 Package Size L x W x H	7400 x 1920 x 2480mm
毛净重 G./N. Weight	4650/4500kgs



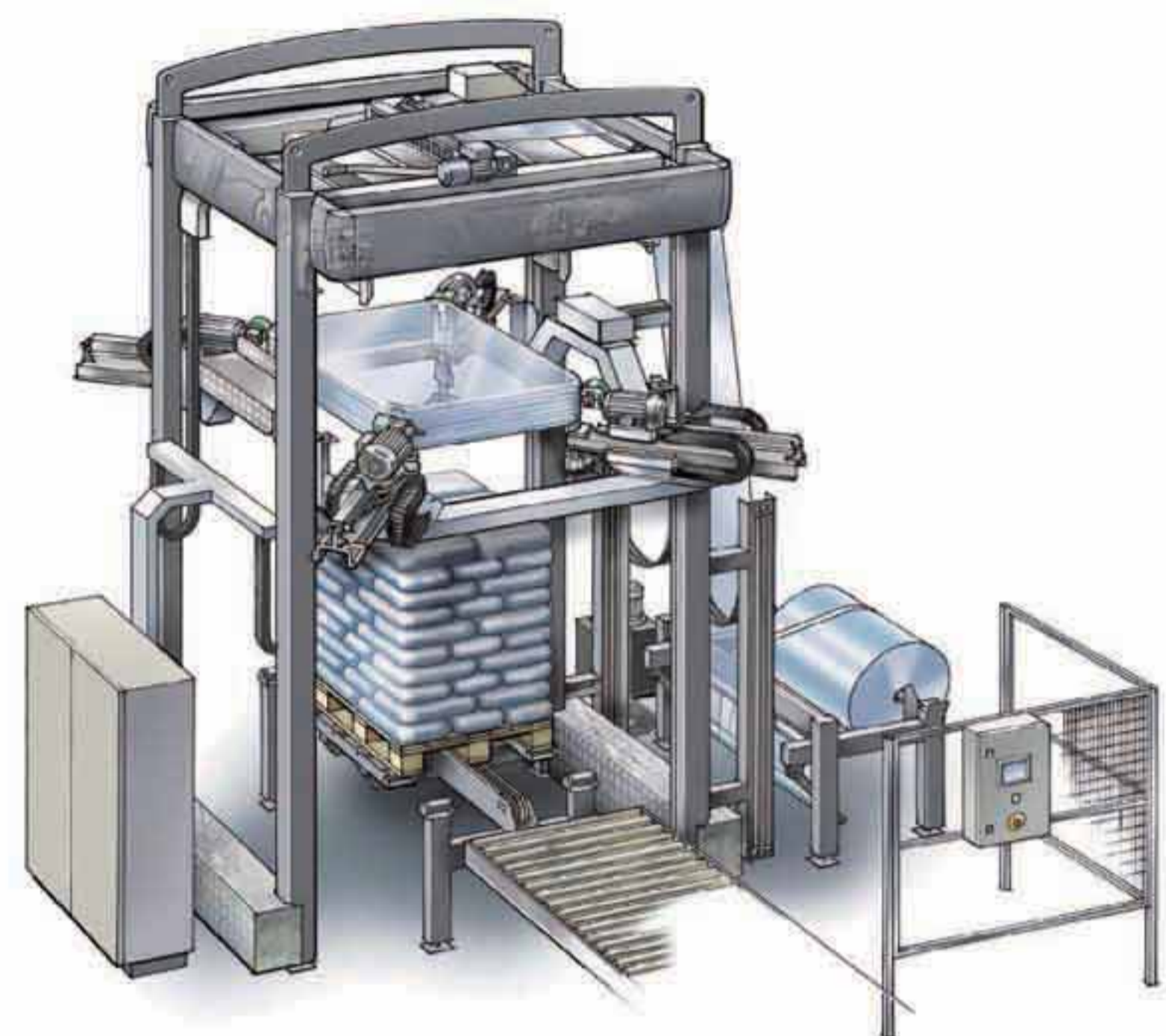

技术参数 Technical Parameter

型号 Model	功率 Power	电源 Power Supply	最大包装尺寸 Max. Package Size L x W x H	载重 Load Weight	包装速度 Packing Speed	工作台高度 Table Height	适用膜 Applicable Film	机械尺寸 Machine Size L x W x H	包装尺寸 Package Size L x W x H	毛重 Gross Weight
SF-CS	6.5kw	AC 380V 3PH 50Hz	1200x1200x1500mm	10000kgs	50-60 pallets/hour	750±50mm	PE stretch hood film	2248x4710x3180mm	5000x2300x1500mm	2500kgs

产品特点 Product Features

- 最大产能每小时60个栈板（依据栈板堆积物的高度而略有不同）；
  - 胶膜顶部封口后形成的袋子可以防水；
  - 适用于运输，堆栈物品被收缩紧密的靠在一起，能有效的防止脱落；
  - 必须割破收缩膜才能拿走堆积的物品，可以降低失窃风险；
  - 适用于0.08mm-0.18mm厚度的PE拉伸膜；
  - 冷拉伸膜不需要使用热能，可节省能源并完全排除火灾或爆炸的危险；
  - 兼具热收缩膜的保护特性和胶膜裹包机的经济特性；
  - 可依据实际需要做不同的设计；
  - 节约能源：可持续发展和生态环境是全球讨论的前提，也是我们从事包装人士面临的挑战，采取实际行动，提供更环保的包装解决方案；
  - 节省空间：空间在当今的生产中往往是非常重要的，特别是狭小的生产面积。此款是专为节能特点而设计，体积小但是效果巨大，具有运行效率和可靠性；
  - 节约膜成本：顶层膜放卷功能可节省高达10%的胶片，并确保低消耗，同时消除了负载角落上的薄膜，使得胶片角度比正常厚约30%。
  - 双头式设计，依据栈的大小自动选择最适当的胶膜；
  - 冷拉伸膜机伸展，套膜是一个循环操作过程；
  - 稳定且坚固模块化结构设计，适合连续操作；
  - 冷拉伸套膜机伸展、套膜是一个循环的过程；
  - 稳定且坚固模块化设计，适合连续操作；
  - 拉伸套膜的透明度比传统的PE膜高，能清楚的看到产品的条形码和标签，能更好的体现产品的广告、展示价值；
- The max production capacity is about 60 pallets per hour (according to the pallet's height, the capacity may have slightly differences);
- The film which is sealed on the top becomes the bag and it is effectively waterproof;
- The products which are packaged together by the film in the pallets are very suitable for transportation. And it can effectively prevent product shedding;
- The products on the pallets which will take away only by cutting the shrink film, so it can reduce the risk of theft;
- For 0.08-0.18mm thickness PE shrink film;
- The machine adopts the most advanced Siemens PLC programmable controller, with safety protection and alarm devices, while the sealing system can have a perfect sealing order without replacement; Maintenance is very simple;
- The machine can be designed according to your requirements;
- Energy saving: Sustainability and environment are at the forefront of the global debate today and we as packaging professionals have faced the challenge of taking practical steps to deliver more environmentally friendly packaging solutions.
- Space saving: Space is often at a premium in today's production, and the small footprint in the packing area. Small in sizes but huge in effect, specially designed for operating efficiency and reliability with energy-saving features;
- Film saving: The top film unwinding feature saves up to 10% film and ensures low film consumption, which also eliminates thin and fragile film on the corners of the load, making the film on the corners approx.30% thicker than normally.
- Double heats design makes the machine can choose the optimum film according to the sizes of the pallets automatically;
- It is a circulation operation process of stretching and hooding in the cold stretch hood machine;
- The modular design is very stable and solid and suitable for continuous working;
- The stretch hood film can protect the products away from water and dust;
- The transparency of the stretch hood film is higher than traditional PE film; you can see the bar code and trademark very clearly. So the advertisements and the exhibition value can be completely showed;

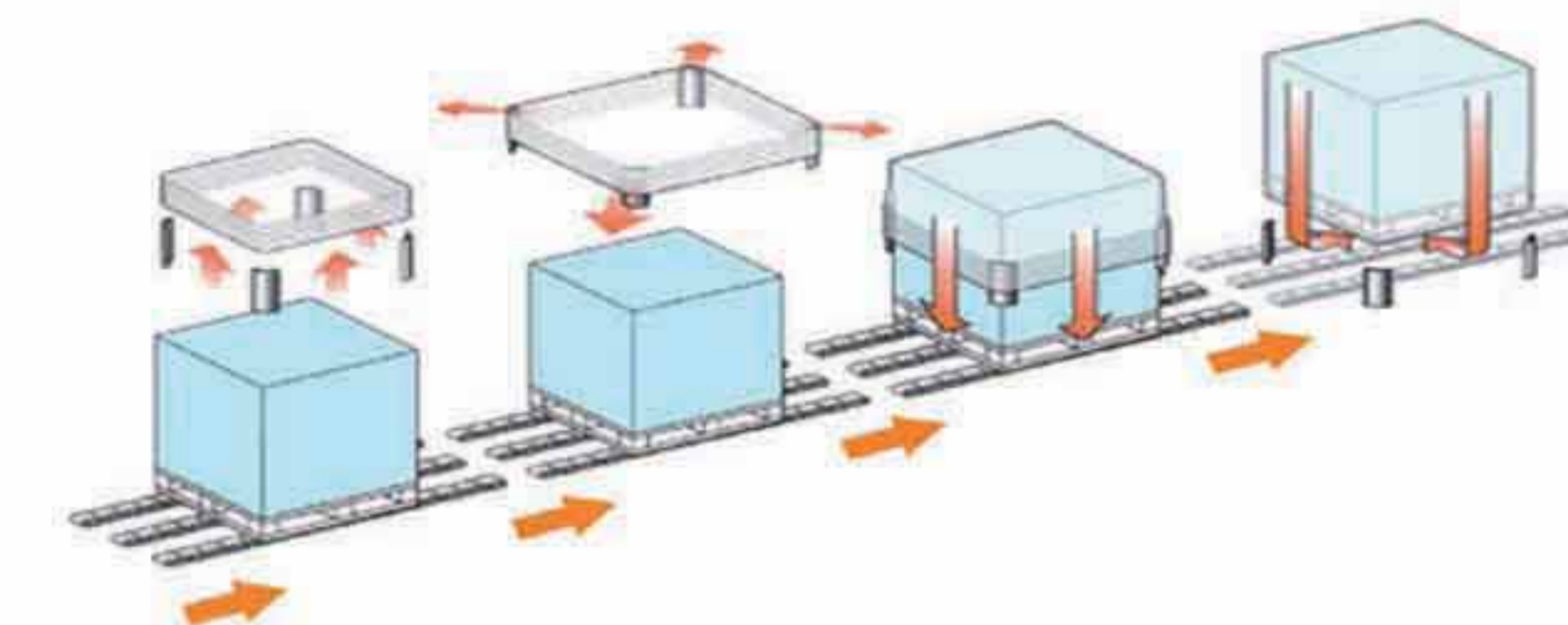



SF-500LA+SF-5030LG 全自动加大L型封切收缩包装机

Enlarge Fully-auto L Bar Sealer & Shrink Tunnel



SF-ZB01+SF-400LA+SF-5030 香盒码垛型封切收缩机

Incense Box Stacking, Sealing & Shrinking Tunnel



GH-3015L+SF-5030 全自动边封切收缩机

Fully-auto Side Sealer & Shrink Tunnel



SF-400LA+SF-4525 铅笔盒封切收缩机

Pencil Box Sealer & Shrink Tunnel



全自动直进料袖口式封切收缩包装机

GH-6030AZS+SF-6040E

Fully-auto High Speed Straight Feeding Sleeve Sealer & Shrink Tunnel



GH-6030AES+SF-6040E 全自动手风琴式封切收缩包装机

Fully-auto Accordion Masking Tape Sealer & Shrink Tunnel



GH-6030AT+SF-23050E 纺织品封切收缩机

Textile Sealing & Shrink Wrapping Machine



GH-5030AR+SF-5030E 翻转型袖口封切收缩机

Overturn Type Sleeve Sealer & Shrink Tunnel





**GH-5030AE+SF-5030LG S.S. 多排型袖口封切收缩机**  
S.S. Multi-rows Type Sleeve Sealer & Shrink Tunnel



**GH-3015L+SF-4525 全自动边封封切收缩包装机**  
Fully-auto Side Sealer & Shrink Tunnel



**GH-6030AB+SF-15060E 水泥发泡板封切收缩机**  
Board Stacking, Sealing & Shrinking Tunnel



GH-3015L+SF-4525

**GH-6030AH+SF-6040E 全自动在线饮料封切收缩机**  
Auto Online Sleeve Sealer & Shrink Tunnel



**全自动袖口式（整体型）封切收缩包装机**  
GH-6030A+SF-15050E  
Fully-auto Sleeve Sealer & Shrink Tunnel Integral Type



**GH-3020LV 全自动纸钞封切收缩机**  
Automatic Banknote Sealer & Shrink Tunnel



**全封闭（对折膜叠膜式）自动封切收缩包装机**  
GH-6030AD+SF-6040E  
Fully-auto Sealing Machine & Shrink Tunnel (Center-folded Film)



**全自动卡簧封切收缩包装机**  
GH-6030AY Automatic Oil Seals Sealer & Shrink Tunnel





SF-300LAC+SF-4525迷你型全自动L型封切收缩包装机  
Mini Fully-auto L Bar Sealer & Shrink Tunnel



GH-6030AF (3000mm)+SF-17040E  
全封闭水平式双边封切热收缩包装机  
Fully-closed Horizontal Double Side Sealer & Shrink Tunnel



SF-400LA+SF-6040E 全自动L型封切收缩包装机  
Fully-auto L Bar Sealer & Shrink Tunnel



SF-60LG+SF-8040E 半自动L型封切收缩包装机  
Semi-auto L Bar Sealer & Shrink Tunnel



GH-8030LH+SF-10040 全自动后置型封切收缩机  
Fully-auto Rear Blade Side Sealer & Shrink Tunnel



SF-20LG+SF-4525 半自动L型封切收缩机  
Semi-auto L Bar Sealer & Shrink Tunnel



GH-6030+SF-6040 半自动袖口封切包装机  
Semi-auto Sleeve Sealer & Shrink Tunnel





板链输送线

Plate Chain Conveyor



不锈钢304转弯输送线

S.S. 304 Turning Conveyor



柔性输送线

Flexible Conveyor



滚筒输送线

Roller Conveyor



皮带输送线

Belt Conveyor



升降机

Lifter



收缩膜

Shrink Film

PE收缩膜 PE Shrink Film



宽度 Width	厚度 Thickness	收缩率 Shrink Ratio		收缩温度 Shrink Temperature	密度 Density	撕裂强度 Tear Strength		拉伸强度 Tensile Strength		断裂伸长率 Elongation	芯管内径 Core Dia.
		横向 Horizontal	纵向 Vertical			横向 Horizontal	纵向 Vertical	横向 Horizontal	纵向 Vertical		
100mm-5000mm	20µm-250µm	5%-55%	50%-80%	150°C-220°C	0.93g/cm³	>40KN/m	>40KN/m	>12MPa	>12MPa	>200%	76mm

国产POF收缩膜

Domestic POF Shrink Film



项目 Items	密度 Density	克重 Weight	摩擦系数 Coefficient of Friction	度 Degree	包装面积 Packing Size	断裂伸长率 Elongation	拉伸强度 Tensile Strength	收缩率 Shrink Ratio	热封温度 Sealing Temperature
单位/Units	g/m³	g/m³	-	%	m²/kg	%	Mpa	%	°C
测定指标值 Determination of Index Values	15µm	0.92	0.2-0.35	2.8	72	105	110	70	120-130
	19µm	0.92	0.2-0.35	3.0	54	100	105	70	120-130
	25µm	0.92	0.2-0.35	3.5	43	100	100	70	120-130
	30µm	0.92	0.2-0.35	3.5	36	100	100	70	120-130

进口交联膜 Imported Cross-linked Film



项目 Items	密度 Density	克重 Weight	摩擦系数 Coefficient of Friction	度 Degree	包装面积 Packing Size	断裂伸长率 Elongation	拉伸强度 Tensile Strength	收缩率 Shrink Ratio	热封温度 Sealing Temperature
单位/Units	g/m³	g/m³	-	%	m²/kg	%	Mpa	%	°C
测定指标值 Determination of Index Values	15µm	0.92	0.2-0.35	2.8	72	105	110	70	120-130
	19µm	0.92	0.2-0.35	3.0	54	100	105	70	120-130
	25µm	0.92	0.2-0.35	3.5	43	100	100	70	120-130
	30µm	0.92	0.2-0.35	3.5	36	100	100	70	120-130